

These instructions contain operating information and should be left with the unit.

**Vapac**<sup>®</sup>

**Resistance Heater Units**  
**Installation & Operation Manual**  
Edition 6

(For use with Software version 8.0 and subsequent issues)

**VapacNet**

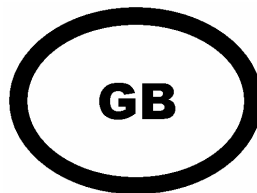

**Installation in countries covered by EC Directives:**

This product will meet the requirements of the Low Voltage Safety Directive 73 / 23 EEC and the EMC Directive 89 / 336 EEC when installed in accordance with the instructions contained in this manual.

Failure to comply with these instructions may invalidate the manufacturer's warranty or any certificate/declaration of conformance requested to be supplied with the unit.

## CONTENTS

1.0	Installation.....	4
1.1	Positioning the Vapac LR unit.....	4
1.1.1	Vapac LR unit dimension layout.....	4
1.1.2	LR weights.....	7
1.2	Positioning the steam pipes.....	7
1.2.1	General.....	7
1.2.2	Steam Hose Connection.....	7
1.3	Plumbing Considerations.....	8
1.4	Electrical Connections.....	9
1.4.1	Important E.M.C. Considerations.....	9
1.4.2	Power Supply Connection.....	10
1.4.2.1	Volt free alarm outputs.....	10
1.4.2.2	Unit control terminals.....	10
1.4.3	Electrical Connections.....	11
1.4.4	Cable Entry Provision.....	11
1.4.5	Vapac Control Circuit Transformer.....	11
1.4.6	RDU Connection.....	11
1.4.7	Cylinder Electrical demand loads.....	12
1.5	Control Circuit Connections.....	13
1.5.1	Control Circuit Wiring.....	13
1.5.2	Proportional Control.....	13
1.5.3	Control Signal Selection.....	13
1.5.4	On/Off Control.....	13
1.5.6	Security Circuit / E.P.O. Shutdown.....	14
1.5.7	Load Shed Option.....	14
1.5.8	Master/Slave System.....	15
2.0	Start-Up / Operation.....	17
2.0.1	Start-up check list.....	17
2.0.2	Start-Up Instructions.....	19
2.0.3	Commissioning/Start-Up.....	19
2.0.4	Features of VAPANET Resistance Heater Unit.....	19
2.1	Service Advice.....	21
2.1.1	Cylinder Inspection.....	21
2.2.1	Feed Valve with Strainer.....	22
2.2.2	Drain Pump.....	22
3.0	Location of Indicators and Controls.....	23
3.1	Positioning of Indicators and controls on Vapac® Vapanet® LR Units.....	23
3.2	Initial Set-up.....	24
3.3	Normal Run / Standby / Start-up – No User Intervention Required.....	25
3.4	Fault / Service Indications – Requiring Operator Intervention.....	26
3.4.1	To Postpone the Service:.....	27
3.4.2	To Service the unit:.....	27
3.5	Other Options.....	28
3.6	Use with LRO unit.....	28
4.0	Trouble-shooting Check List.....	29
5.0	Wiring Diagram.....	30
Appendix 1.		
A Guide to Positioning Steam Pipes:.....		44
Appendix 2.		
A Guide to Positioning Multipipes:.....		46

## **Important Installation Points**

The unit must be installed to comply with national regulations and/or codes of practice. A qualified electrician must carry this out.

Ensure at least 1000 mm clear front access to the electrical and steam sections of the cabinet.

Do not locate the cabinet where the ambient temperature around the unit could exceed 35°C or fall below 5°C e.g., an unventilated roof mounted enclosure – see minimum space / ventilation requirements page 5.

Do not locate the cabinet where a ladder is required for service access as this could make servicing and cylinder service or exchange hazardous.

Make sure steam line(s) have adequate slope (min 12%) for condensate drainage and use condensate separators if the pipe is lower than the unit.

Provide adequate support to prevent sags developing in flexible steam lines, which can fill with water and create a "trap".

Do not locate vented drain directly under the cabinet.

It is important to select the correct water type, see table on page 8, your water supply company should be able to provide the required information free of charge.

## **Important Electrical Connection Items**

Before commissioning the unit, check that all electrical (power) connections - including those at the terminals and contactor are tight.

Check that the transformer primary winding connection is correct for the supply voltage at Vapac terminals A1 & A2.

The Vapac transformer must not be used to power other equipment.

To comply with EMC aspects see recommendations on page 9.

Use a high-limit humidistat to ensure positive interruption of unit operation when over-humidification is detected (see p14).

It is important that the control signal connected to terminals 5 & 6 must be referenced to ground at the control PCB – this can be done by linking either terminal 5 or 6 to terminal 7.

NB if the controller output is referenced to ground, it is important that the "leg" which is connected to ground at the controller is also connected to ground at the Vapac unit. Grounding the opposite "leg" will cause damage to the controller and/or the Vapac control PCB.

## **Important Maintenance Items**

Only a qualified electrician should carry out maintenance.

The boiler contains hot water, and must be drained before any maintenance is carried out on the steam section. This should be done prior to isolating the power, and removing the front access panel

**ESD SENSITIVE DEVICES USED ON PCB. ENSURE ANTI-STATIC PRECAUTIONS ARE TAKEN WHEN REMOVING OR REPLACING PCB'S.**

**1.0 Installation.**

**1.1 Positioning the Vapac LR unit**

**1.1.1 Vapac LR unit dimension layout**

**Do's**

- Do** mount the unit as close to the steam distribution pipe(s) as possible.
- Do** mount the unit at a height convenient for reading the display window.
- Do** ensure adequate side ventilation (min 80 mm).
- Do** ensure adequate service access to the front of the unit (min 1000 mm).
- Do** ensure adequate service access below the unit (min 1000 mm).
- Do** ensure that the holes in the rear top panel remain unobstructed to allow a free flow of air see fig 1.
- Do** use the marking on the side of the carton as a template to mark the mounting hole positions.
- Do** remove the cylinder, if necessary, to access the mounting holes in the back of the steam section.
- Do** use M6 projecting type wall bolts or equivalent to mount the unit in position.
- Do** mount units with RDU's so that steam pipe discharge is above head height.
- Do** leave minimum gap between the top of an RDU and the ceiling as per table in fig 3.

**Don'ts**

- Don't** mount the unit close to sources of strong electro-magnetic emissions e.g. variable speed lift motor drives, kVa transformers etc.
- Don't** mount the unit in an unventilated enclosure.
- Don't** mount in a position requiring ladder access to the unit.
- Don't** mount the unit behind a false ceiling or other situation where an unusual malfunction (e.g. water leak) would cause damage.
- Don't** mount the unit in an area which will be hosed down.
- Don't** install the unit where the ambient temperature can exceed 35°C; or fall below 5°C.
- Don't** mount the unit inside a cold-room or other place where temperature and humidity conditions can cause condensation on electrical components.
- Don't** mount the unit where the sound of a contactor opening/closing and water flow in a pipe would be unacceptable e.g. libraries, private apartments, etc.
- Don't** position an RDU to discharge directly over expensive equipment, desks or stored materials.

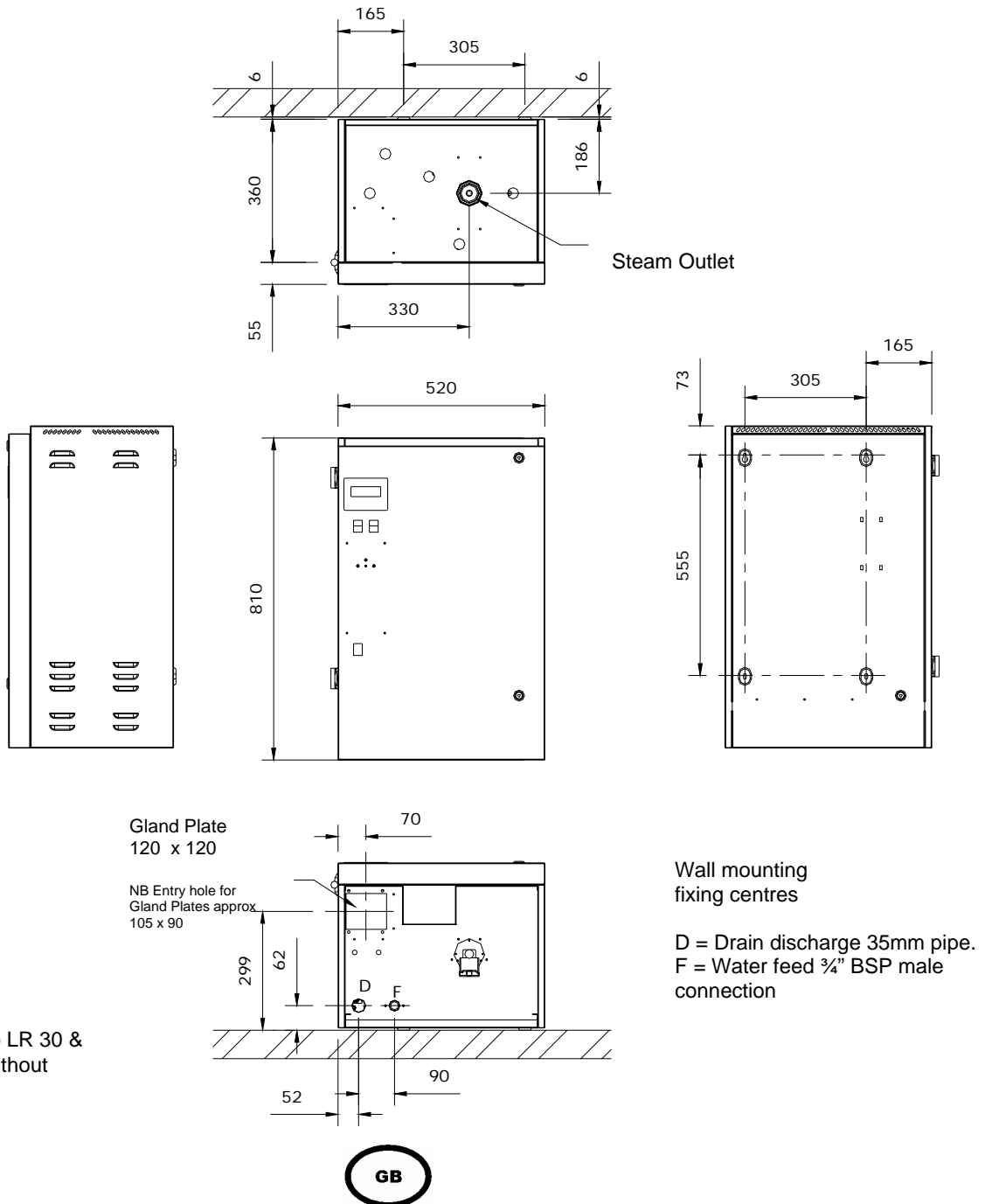

**Fig 1** LR5 & LR5P to LR 30 & LR30P units with or without RDU fitted.

**Fig 2** LR5 & LR5P to LR 30 & LR30P RDU

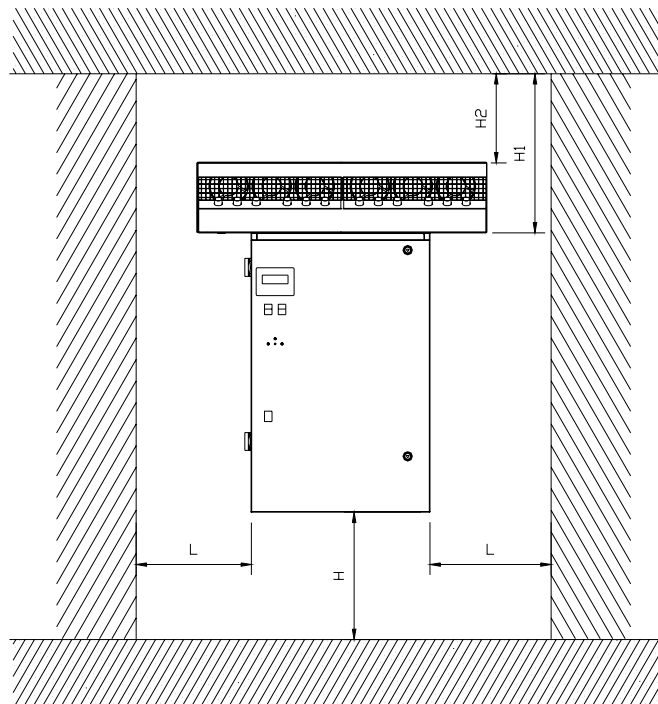
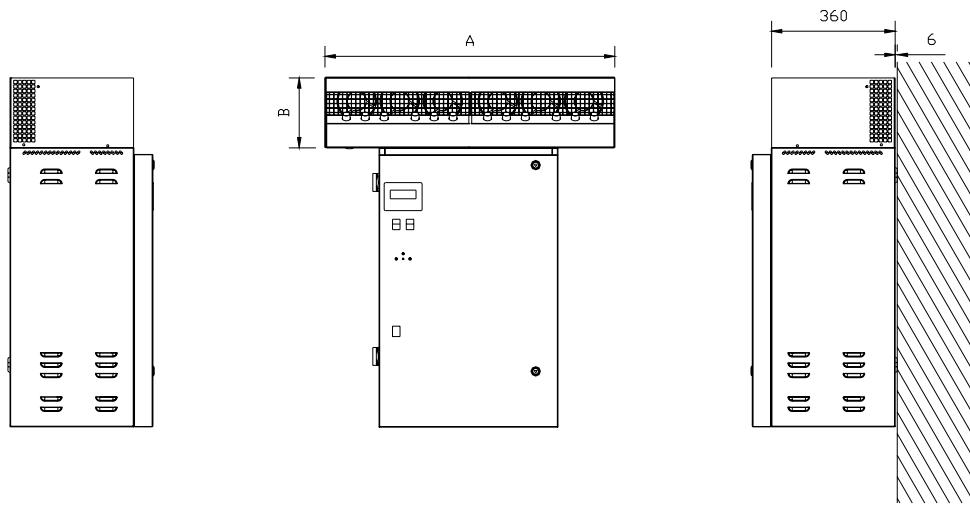

**Within the area of H1 or H2 above the unit nothing must protrude out from the wall, as this will effect the natural ventilation path of the Unit.**

**Fig 3** Clearances around LR units.

LR UNIT	A	B	L	H min	H1	H2
LR5 & LR5P	377	205	80	1000	500	200
LR10 & LR10P	377	205	80	1000	500	250
LR20 & LR20P	435	205	80	1000	500	500
LR30 & LR30P	602	205	80	1000	500	750

**Fig 4 LR40 & LR40P to LR 60 & LR60P**

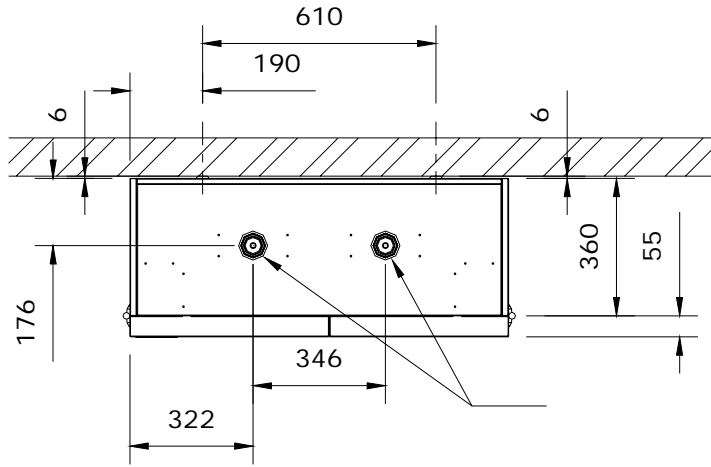

Steam outlet pipes position.

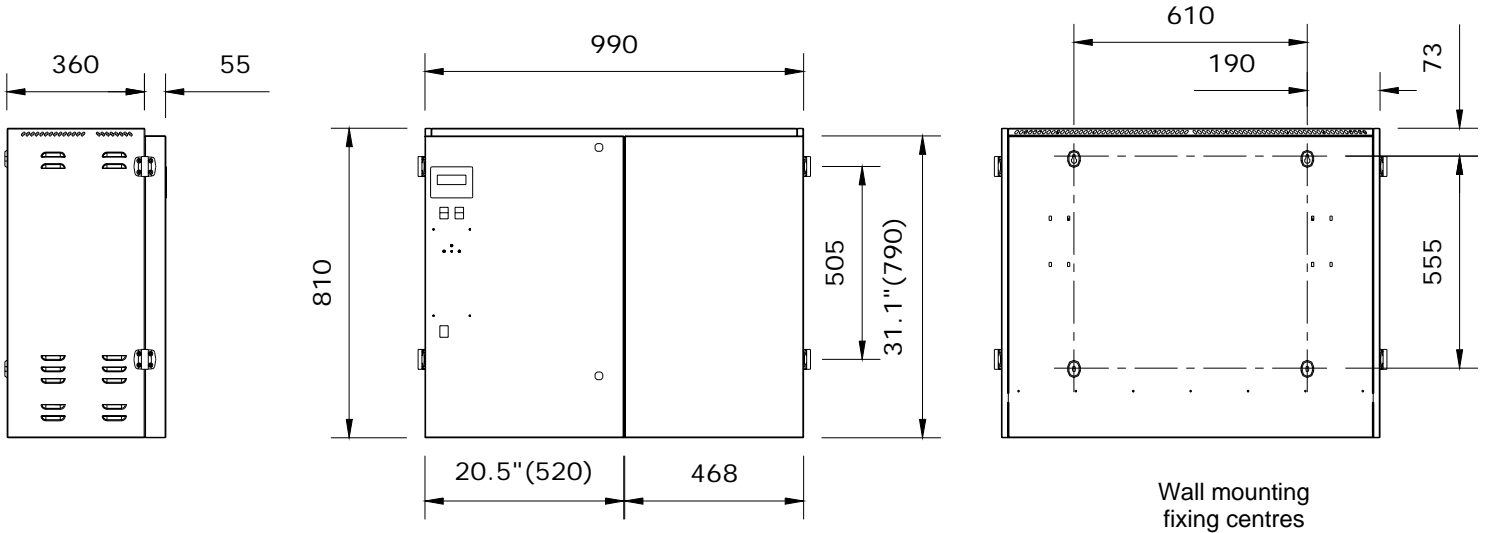

Wall mounting fixing centres

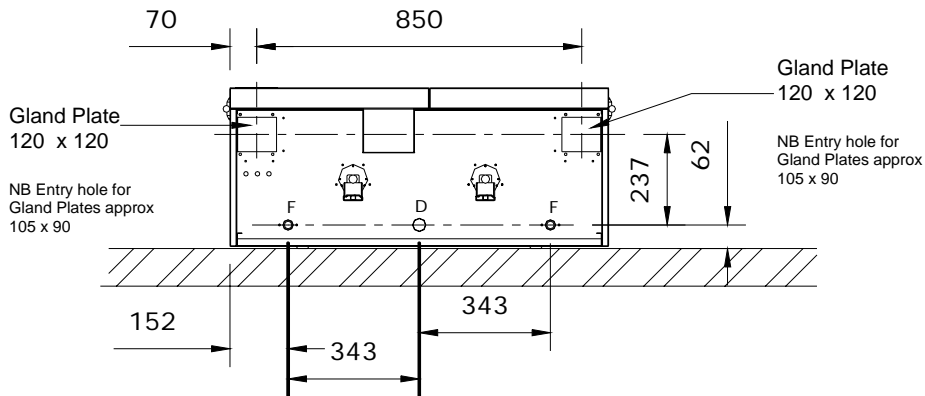

D = Drain discharge  
35mm pipe.

F = Two water feed 3/4"  
BSP male connection  
Note:- RDU units  
cannot be fitted to LR40 &  
LR40P to LR60 and  
LR60P units

LR40, LR40P, LR50, LR50P, LR60, and LR60P units  
have the same minimum recommended dimension as  
follows:

L	100
H	1000
H1	600

**Note:**  
L, H & H1 refer to dimensions shown in Fig 3 on page 5.



## 1.1.2 LR weights

The unit dry weight is the delivered unit with no water in unit, the wet weight is the operational weight when the unit is running. The RDU weight must be added to the unit weight if fitted on top of the Resistive unit.

Resistive model	Dry Kg	Wet Kg	RDU Kg
LR5 and LR5P	34	48	6
LR10 and LR10P	35.5	49.5	10
LR20 and LR20P	39	65.5	12
LR30 and LR30P	40	66.5	14
LR40 and LR40P	72.5	125.5	NA
LR50 and LR50P	73.5	126.5	NA
LR60 and LR60P	74.5	127.5	NA

## 1.2 Positioning the steam pipes

### 1.2.1 General

Steam pipes should be positioned as shown below, allowing a minimum rate of fall back to the unit of 12% to allow the free flow of condensate back to the unit. If the above fall is not possible, then condensate separators must be fitted as shown in figure 1.

The position of the steam pipe or multipipe in a air-conditioning system relative to other items such as bends, filters, heat exchangers, etc., is critical. The steam pipe must not be located closer to such item, than the entrainment distance, and must be decided by the design engineer responsible for the project.

#### Do's

- Do** obtain project engineer's instruction/drawing for chosen location of pipe
- Do** obtain project engineer's instruction/drawing for pipe position relative to the top & bottom of the duct (or sides if airflow is vertical).
- Do** check if alternative slope of Ø35mm pipe has been specified requiring rotation of pipe in its socket before installation.
- Do** use bracket/lug on the end of Ø54mm pipes for extra support.

### 1.2.2 Steam Hose Connection

#### Do's

- Do** use Vapac steam hose or well insulated copper pipe.
- Do** keep steam hose as short as possible (under 2m for max efficiency).
- Do** arrange to have a vertical rise immediately over the unit of 300mm.
- Do** use the full height available between the unit and steam pipe to provide maximum slope (min 12-20% for condensate to drain back to the steam cylinder (or down to a condensate separator). Always provide a continuous slope.
- Do** provide adequate support to prevent sagging
  - a) fit pipe clips every 30-50cm
  - or b) support straight lengths on cable trays or in heat resistant plastic pipe.
- Do** ensure radius hose bends are fully supported to prevent kinks developing when in service.
- Do** add extra insulation to steam hose for longer runs (2m-5m) and in cold ambient conditions to avoid excess condensate and reduction in delivered output.

#### Don'ts

- Don't** allow steam hose to develop kinks or sags.
- Don't** include horizontal runs or 90° elbows in the steam line.

Steam Distribution Pipe requirement			
Resistance Heater Unit Model	LR05 LR10 LR05P LR10P	LR20 LR30 LR20P LR30P	LR40 LR50 LR60 LR40P LR50P LR60P
35mm Ø Pipe No.	1	-	-
54mm Ø. Pipe No.	-	1	2
* Duct Pressure Pa.	+2000 -600		+2000 -600

\* For systems with a duct pressure over +1000 Pa. It may be necessary to fit a suitably sized trap in the water feed line between the Vapac tundish and the feed drain manifold to ensure water can enter the cylinder when it is empty.

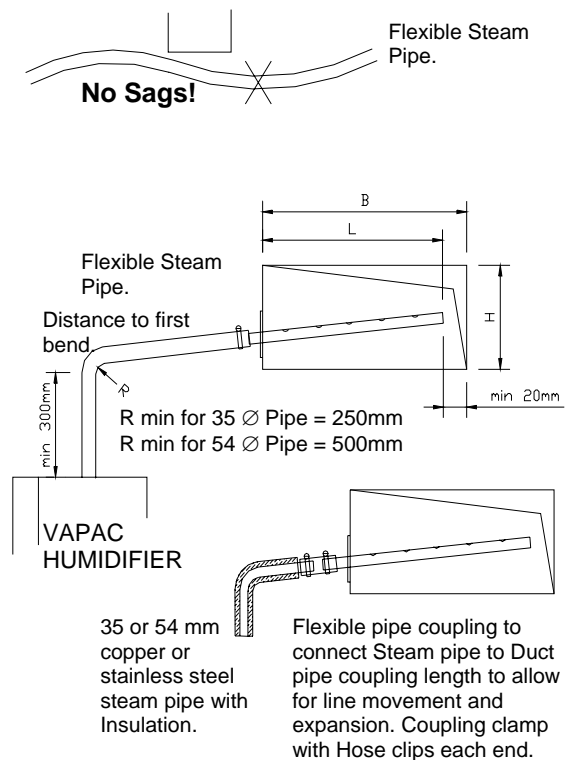

Fig 6

35mm Ø Pipe Selection		54mm Ø Pipe Selection	
Duct width B mm	In-duct Length L mm	Duct width B mm	In-duct Length L mm (Kg)
320-470	300		
470-620	450		
620-770	600		
770-920	750	700-950	650 (1.8)
920-1070	900	950-1450	900 (2.2)
1070-1200	1050	1450+	1400 (3.2)

**For guidance on positioning of steam pipes see Appendix 1.**

**For guidance on use of Multipipes see Appendix 2.**

### 1.3 Plumbing Considerations.

#### 1.3.1 Cold water supply.

**General**

The Resistance Heater range of units is capable of operating with a range of water quality raw mains or de-mineralised/de-ionised. The water supply should be within the following limits:-

<b>Conductivity</b>	<b>0 – 1000µS</b>
<b>PH</b>	<b>7.3 – 8.0</b>
<b>Silica</b>	<b>0</b>
<b>Pressure of between</b>	<b>1 - 8 bar.</b>
<b>Maximum chloride level</b>	<b>170 ppm</b>

Water Supply rates		
1.70 l/min	LR05	LR05P
1.70 l/min	LR10	LR10P
2.00 l/min	LR20	LR20P
2.50 l/min	LR30	LR30P
4.00 l/min	LR40	LR40P
4.50 l/min	LR50	LR50P
5.00 l/min	LR60	LR60P

**Do's**

- Do** install a stop-valve/Shut-off valve and a strainer close to the unit.
- Do** provide a water supply with sufficient pressure and pipe size to ensure an adequate flow rate to all units connected to the system.
- Do** use the water connection with nylon nut provided.

ALL Dimensions in mm

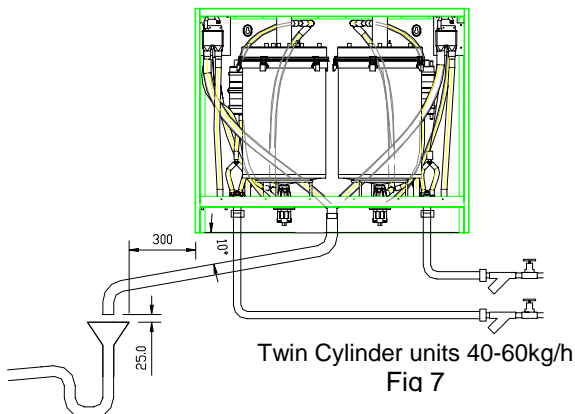
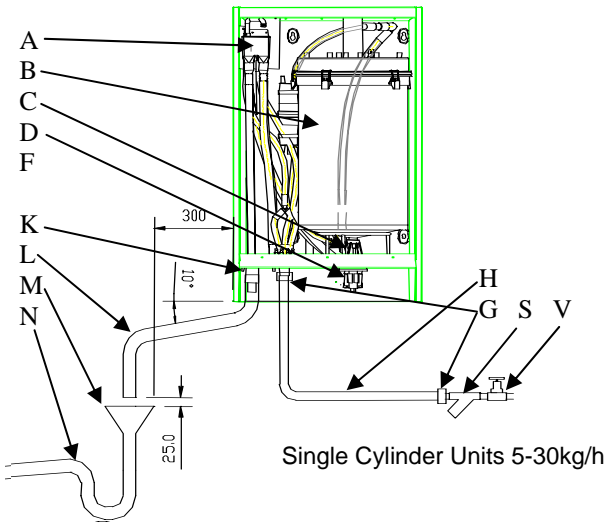

Water type Selected	Conductivity range µS	Max. Chlorine level ppm
De-mineralised	< 50	
De-ionised	50 – 100	< 80
Softened	100 – 200	80 – 100
Potable (Low conductivity)	200 – 300	100 – 150
Potable (Med. conductivity)	300 – 500	> 150
Potable High conductivity	> 500	

Generally the water type will be selected by the conductivity levels, however they should be modified as shown, e.g. conductivity of 75µS and chlorine level of 85 ppm the correct setting is Softened".

**Don'ts**

**Don't** use a wrench or other tool to tighten the water supply connection - the nylon nut and rubber washer provided, should only require tightening by hand to effect a seal. If water seepage occurs, undo the nut to wipe the washer clean and re-seat it.

#### 1.3.2 Drain connection.

**General**

**Do's**

**Do** ensure metal drain and supply water pipework is grounded electrically close to the unit (a ground/earth stud is positioned on the underside of the cabinet.

Drain capacity per cylinder	= pump discharge rate of max 16.8 l/min at 50 Hz.
Power supply	17.2 l/min at 60 Hz.

**Do's**

- Do** use copper or plastic pipe rated for 100 °C.
- Do** arrange to discharge drain water from the unit into a trapped and vented drain at a position where flash steam rising from the drain line vent will not pose a problem for the Vapac or other equipment.
- Do** provide adequate fall for the drain pipework to allow free flow of water drained from each unit.
- Do** ensure drain line pipe size will accommodate water being drained at the same time from all the Vapac units which are connected to it.

KEY: -

- A Tundish Fill-cup
- B Steam Cylinder
- C Feed Drain Manifold
- D Drain Pump
- F Feed Solenoid Valve
- G Water Connection 3/4" BSP.
- H Flexible hose 3/4" BSP.
- K 35Ø Steam Hose coupling and Hose Clips.
- L 35Ø copper or plastic Drain for 110°C Water with supports.
- M Tundish
- N U-trap side exit.
- S Optional Strainer
- V Isolation stop cock

1.4 Electrical Connections

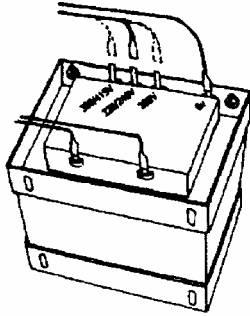

**Important Power Connection Information**

Vapac 24V and 9 V secondary Transformer Primary supply connections:  
 Vapac units are wired to allow connection to alternative site Voltages.  
 Make the following simple checks before connecting the power supply:-  
 Move the RED connection on the VAPANET transformer primary winding circuit to the position marked with the supply Voltage that is to be connected between VAPANET power terminals A1 and A2.  
 The transformer primary circuit terminal positions are clearly marked:- 200V, 230V, 380, 415 & 440V. **If the actual (measured) site voltage is 400v the preferred tapping is 380V.** The transformer is fitted below the Drain tray, and is accessible by removing two screws and the cover, which should be slid it towards you.

**Note:**

- 24 V a.c. Control circuit - 6.3 A 20 mm (T – Time Lag) fuse (Pt.No. 1080093)\_mounted on VAPANET Echelon PCB (Pt.No.1150630).
- 9 V a.c. PCB Circuit - 2 A 20 mm (F - Quick blow) fuse (Pt No. 1080099) mounted on the VAPANET Echelon PCB (Pt, No. 1150630).
- Transformer Primary Circuit - Two fuses protect the control circuit on Single cylinder units F1 2.0A (slow blow) (Pt. No. 1080095) mounted in fuse-terminal holder protects Primary transformer and RDU unit if fitted. F2 500 mA 20 mm (F - Quick blow) fuse (Pt No. 1080054) mounted in fuse-terminal holder protects Transformer Primary and Pump or both pumps if two pumps are fitted.
- 230V ac Pump Supply. - The pump or pumps on twin cylinder units are fed from the main transformer via a 230 volt auto winding. The pumps are protected by fuse F1 and F2 above feeding the transformer primary.

1.4.1 Important E.M.C. Considerations

Use a dedicated, earthed metal conduit for both the control signal cable and the security circuit cables along their entire length - they may share the same conduit where practicable. The earth must be made by "metal-to-metal" contact and should be a good RF (Radio Frequency) earth.

The control and security circuit connections should be run in screened cable with the screen grounded at the VAPANET end (onto the electrical section back panel). The screen should be maintained as close as possible to the cable ends and any tail between the screen and the earth point must be kept short (50 mm maximum).

**Control Cable / Security Circuit Conduit Entry Arrangement**

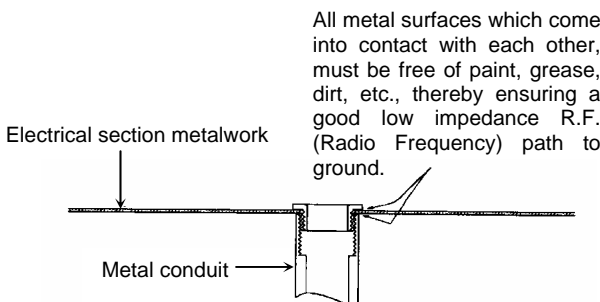

**Control Cable / Security Circuit Screening Arrangement**

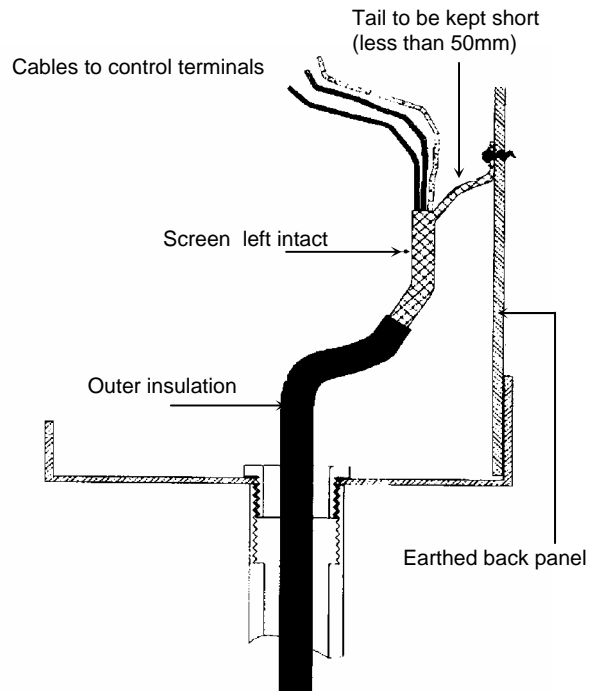

### 1.4.2 Power Supply Connection

The unit requires the following connections as shown in the diagram below

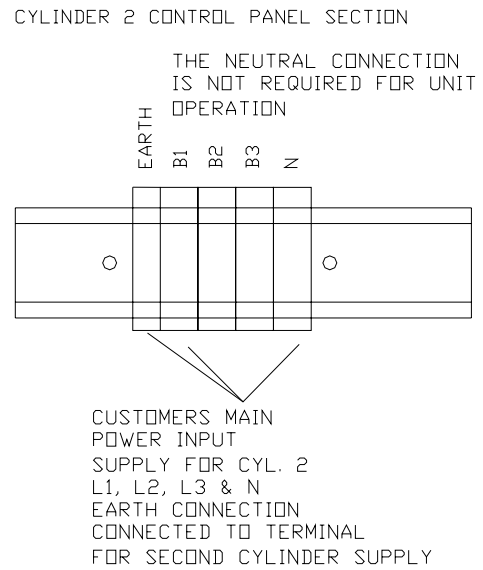
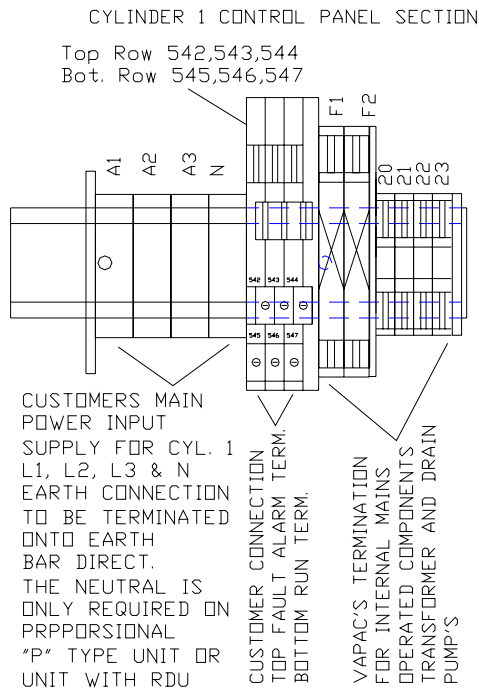

#### 1.4.2.1 Volt free alarm outputs

The unit has connections for volt free alarm outputs these are on the three double terminals next to the main power input terminals.

The top terminals are for unit volt free fault alarm as follows:

- 542 common for fault alarm
- 543 Normally closed when no fault
- 544 Normally open when no fault

The bottom terminals are for unit volt free run signal as follows:

- 545 Common for run signal
- 546 Normally closed when unit is in standby or fault (not running)
- 547 Normally open when unit is in standby or fault (not running)

If the unit is part of a master slave system or network, the run & fault outputs can be selected (via keypad & display) as either network (system) or unit only. This is selectable at Service Engineers Level, in the Engineering Menu, in the window "Fault/Run Scope". The default is "network". It is possible to get both alarm & Run indication in all units: Single cylinder units will give this indication if the service interval has expired; Twin Cylinder & Networked units will give this indication if the service interval has expired or if the master cylinder is operating and any slave cylinder (or cylinders) are in fault.

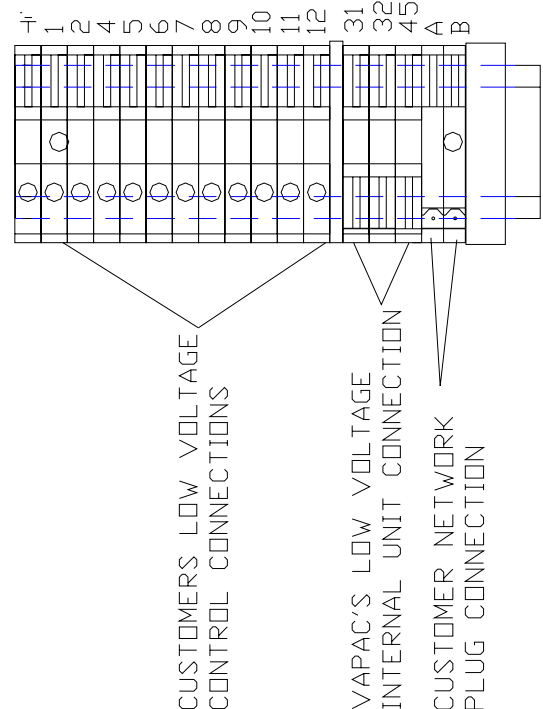

#### 1.4.2.2 Unit control terminals

For unit control and network termination see section 1.5 the terminal layout is shown.

### 1.4.3 Electrical Connections

The wiring to the Vapac should be done by a qualified electrician. The external overcurrent protection and wiring should comply with the appropriate Regulations and Codes of Practice.

**Important:** Make sure the connection to the primary Voltage winding of the Vapac transformer matches the supply Voltage which is to be connected between Vapac terminals A1 & A2. If the actual (measured) site voltage is 400v the preferred tapping is 380V.

A fused disconnect/isolator or MCB should be used to disconnect the supply from all electrodes simultaneously.

This must be sized to suit the total maximum phase/line current of the unit and should be located adjacent to the Vapac cabinet or within easy reach and readily accessible.

In Vapac VAPANET units terminals 1, 2 and 3 are for the power supply connections as indicated in the diagrams below.

Twin cylinder units' have terminals for the connection of two power supply input circuits. On twin cylinder units' this allows individual external protection of each steam cylinder. Fused disconnect/isolator or MCB provision must be linked to ensure both 3 phase supply inputs are disconnected simultaneously.

### 1.4.4 Cable Entry Provision

Cable glands must be used to ensure cables are held securely at the entry position. All Vapac cabinets are equipped with a removable gland-plate. The installing electrician should remove this and take it to a work-bench to drill for the required cable gland size.

### 1.4.5 Vapac Control Circuit Transformer

The internal control circuit of the Vapac unit operates at 24Vac - the transformer secondary is set at 24V.

As standard the Vapac VAPANET includes a transformer with alternative primary winding options 200V, 230, 380, 415, and 440V and requires on site adjustment to match it to the Voltage connected to Vapac terminals A1 and A2.

The transformer also has a 9V secondary tapping which provides power to the VAPANET 1150630 PCB.

**Important:** The Vapac transformer must **NOT** be used to power other equipment or the warranty will be invalidated.

### 1.4.6 RDU Connection

Vapac terminals 25 & 26 are included to provide a 230Vac electrical supply for the fan motor in the RDU (Room Distribution Unit) .

Note: The 230Vac at terminals is derived from the incoming electrical supply to the Vapac. If the local supply cannot provide 230Vac (example 400V No Neutral supply) it will be necessary for a transformer to be fitted in the RDU as indicated below.

**Notes:-**

1. All units must have a PE earth connection connected to the units terminal.
2. Unit with N.A. in the following tables means NOT AVAILABLE there is not a unit available to run at the voltage and phases shown. Please check that the correct model reference is ordered and installed, for the low or high voltage required, and at the desired steam output.
3. Standard design is for 50 Hz. Supplies. Design for 60 Hz. Also available - 60 Hz. Supply must be specified with order as the standard pump is only 50Hz.

**FOR FULL ELECTRO-MAGNETIC COMPATIBILITY A NEUTRAL CONNECTION IS REQUIRED FOR ALL PROPORTIONAL UNITS AS INDICATED IN THE CONNECTION DIAGRAMS ON THE FOLLOWING PAGES.**

**RDU Connection**

The three type's of RDU are for various voltages and phase without neutrals connections that can be made to the Microvap unit. Please refer to the Microvap connection diagram on the following three pages as to which type of unit is required. On twin cylinder units two fan circuits as shown below one for each cylinder will be in the RDU unit.

RDU electrical load

Model	RDU05LR	RDU09LR	RDU20LR	RDU30L
Number of fans	2	3	3	5
Fan voltage	230 v	230 v	230 v	230v
Each fan current 50Hz (60 Hz)	115 mA (105 mA)	115 mA (105 mA)	115 mA (105 mA)	115 mA (105 mA)
RDU total load current 50Hz (60 Hz)	225 mA (210 mA)	345 mA (315 mA)	345 mA (315 mA)	575 mA (525 mA)

200 – 250 V 1Ph. N + earth

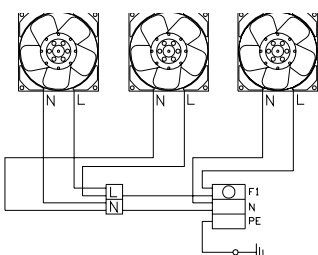

200 – 250 V 2Ph. + earth

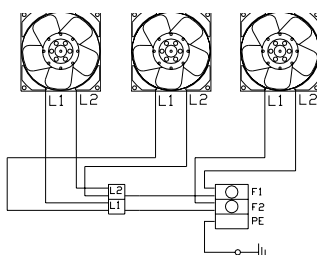

380 – 440 V 2Ph + earth

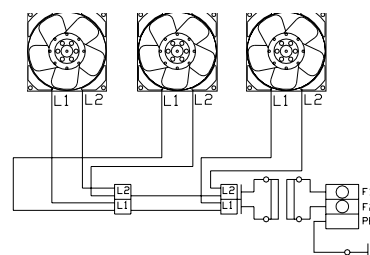

TRANSFORMER  
PRIMARY  
380 – 440 V  
SECONDARY  
210 – 250 V

1.4.7 Cylinder Electrical demand loads

		5 Kg/hr Cylinder			10 Kg/hr Cylinder						
		200	230	250	200	230	200	230	380	415	440
Voltage	V	200	230	250	200	230	200	230	380	415	440
Nominal cylinder size	Kg/hr	5	5	5	10	10	10	10	10	10	10
Electrical Supply		Ph+N	Ph+N	Ph+N	Ph+N	Ph+N	3Ph	3Ph	3Ph	3Ph	3Ph
No. of elements		1	1	1	3	3	3	3	3	3	3
Element Resistance	ohms	13.7	13.7	13.7	20.9	20.9	20.9	20.9	20.9	20.9	20.9
Element connection		direct	direct	direct	Par/star	Par/star	DELTA	DELTA	STAR	STAR	STAR
Element Material		Incoloy 800	Incoloy 800	Incoloy 800	Incoloy 800	Incoloy 800	Incoloy 800	Incoloy 800	Incoloy 800	Incoloy 800	Incoloy 800
Full load Current	A	14.6	16.8	18.2	28.7	33.0	16.6	19.1	10.5	11.5	12.2
Power rating	Kw	2.92	3.861	4.562	5.742	7.593	5.742	7.593	6.909	8.240	9.263
Max. Output	Kg/hr	3.96	5.24	6.19	7.79	10.3	7.79	10.3	9.37	11.17	12.56
Fuse Rating/phase	A	20	20	20	32	40	20	25	20	20	20
Supply cable terminals	mm <sup>2</sup>	4	4	4	16	16	16	16	10	10	10

		20 Kg/hr Cylinder					30 Kg/hr Cylinder				
		200	230	380	415	440	200	230	380	415	440
Voltage	V	200	230	380	415	440	200	230	380	415	440
Nominal cylinder size	Kg/hr	20	20	20	20	20	30	30	30	30	30
Electrical Supply		3Ph	3Ph	3Ph	3Ph	3Ph	3Ph	3Ph	3Ph	3Ph	3Ph
No. of elements		6	6	6	6	6	6	6	6	6	6
Element Resistance	ohms	20.9	20.9	20.9	20.9	20.9	13.7	13.7	13.7	13.7	13.7
Element connection		DELTA	DELTA	STAR	STAR	STAR	DELTA	DELTA	STAR	STAR	STAR
Element Material		Incoloy 800	Incoloy 800	Incoloy 800	Incoloy 800	Incoloy 800	Incoloy 800	Incoloy 800	Incoloy 800	Incoloy 800	Incoloy 800
Full load Current	A	33.1	38.1	21.0	22.9	24.3	50.6	58.2	32.0	35.0	37.1
Power rating	Kw	11.483	15.187	13.818	16.481	18.526	17.518	23.168	21.080	25.142	28.263
Max. Output	Kg/hr	15.57	20.59	18.74	22.35	25.12	23.75	31.41	28.58	34.09	38.32
Fuse Rating/phase	A	40	40	32	32	32	63	63	40	40	40
Supply cable terminals	mm <sup>2</sup>	16	16	10	10	10	16	16	10	10	10

Resistive unit model reference	LR5 and LR5P	LR10 & LR10P	LR20 & LR20P	LR30 & LR30P	LR40 & LR40P	LR50 & LR50P	LR60 & LR60P
Cylinder 1 Size Left hand power feed	5	10	20	30	20	30	30
Cylinder 2 Size Right hand power feed	None	None	None	None	20	20	30
Number of Power supplies to unit	1	1	1	1	2	2	2

Note :- Cylinder 1 power supply equals Cylinder load from table above plus 1amp for control (feed valves and drain pumps ) plus RDU load from 1.4.5 on page 8 if fitted.

### 1.5 Control Circuit Connections

#### 1.5.1 Control Circuit Wiring

Use a dedicated, earthed metal conduit for both the control signal cable and the security circuit cables, sharing the same conduit if practicable.

Use screened cable for all control and security circuit connections to minimise risk of electrical interference. The screen should be grounded at the VAPANET end only. See detail on page 7. NB. The control signal should be connected to ground at the PCB by connecting either terminal 5 or 6 to terminal 7 – **Important note if the controller output is referenced to ground, then the “leg” which is ground must be the one linked to terminal 7.**

#### 1.5.2 Proportional Control

The VAPANET Electrode Boiler (LEXP) models can all be operated by either a potentiometric signal, a Lonworks network signal or by one of 6 standard proprietary DC analogue signals.

Input signal:

- Potentiometric control
- 0-5V
- 0-10V
- 0-20V (Actually 0-18V – not phase cut)
- 2-10V
- 1-18V
- 4-20mA (Ensure jumper J1 is in place)
- Network (Slave unit – demand generated by Master)

Response:

8-100%

#### 1.5.3 Control Signal Selection

Selection of the control signals is done a part of the initial set-up procedure using the keypad display. For confirmation that the signal has been selected, view the information window. If the unit has not got a keypad then this is done on the configuration board 1150634 mounted on the main control board 1150630 using the jumpers provided. The appropriate right hand link should be made to select the site feed water type and the appropriate left hand link representing the actual site control signal should be linked using the jumper plugs provided.

#### 1.5.4 On/Off Control

Vapanet models can be operated by a single step humidistat which has Volt-free contacts – select control option Pot.

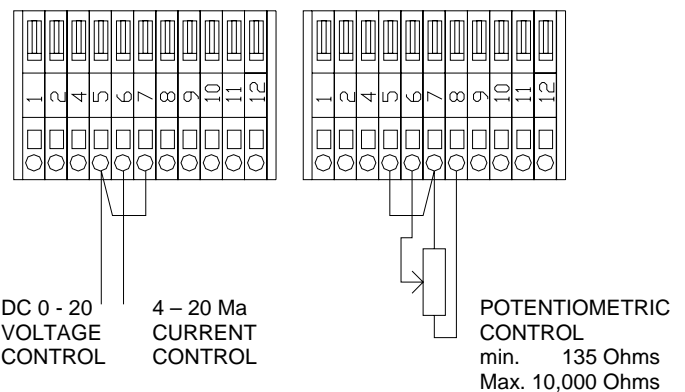
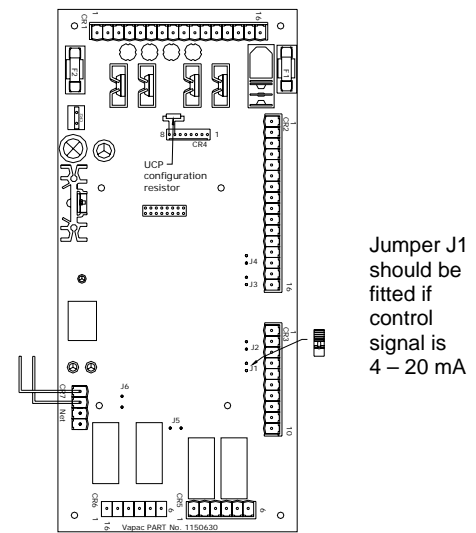

**NOTE :- FOR CURRENT INPUT ONLY JUMPER J1 ON THE 1150630 CONTROL BOARD MUST BE LINKED.**

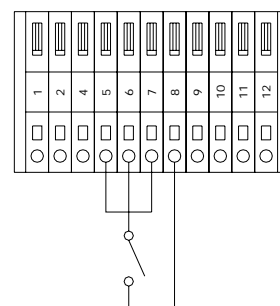
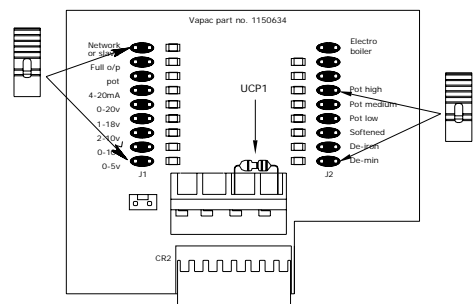

**HYGROSTAT WITH VOLT FREE CONTACTS (max. RESISTANCE OF EXTERNAL CONNECTION 100 Ohms.**

**1.5.5 Sensing Head**

The units are designed to operate using a sensing head, supplied by Vapac Humidity Control Ltd. which should be connected as shown below. **Other propriety sensing heads which give a DC signal may also be used, providing the control signal is connected to control terminals 5 & 6, and the sensing head is powered externally from the unit.**

If “Frost Protection” is required do not connect the thermistor input from the sensing head to control terminals 1 & 2, which should be used to connect the “frost protection thermistor” (part number 1220275) instead. Frost protection is selected via the display – Set the frost demand above the minimum cylinder demand (LE units >20%; LE(P) & LE(C) units >8%)

**Note:**

**Use of the 24V supply of the VAPANET unit to power other items of equipment will invalidate the Vapac warranty.**

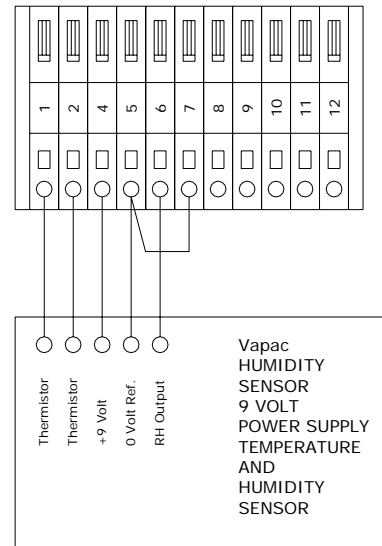

Vapac’s accessory kit part numbers for sensors are Remote Room mounted sensing head FVKIT-107 And Remote Duct mounted sensing head FVKIT-108

**1.5.6 Security Circuit / E.P.O. Shutdown**

As standard units are shipped such that terminals 9 & 10 are provided for connection of an E.P.O. (Emergency Power Off) switch or fire shutdown facility. Other control interlocks, such as high limit humidistat, airflow switch and/or fan interlock and time switches etc. should be connected to terminals 11 & 12. **Please note that if a display is connected to the unit “DI1 Control Option” must be set to “Shutdown”.**

**NB breaking terminals 9 & 10 will prevent any unit operation including frost protection.**

**1.5.7 Load Shed Option**

This can only be evoked via a display, either “hard wired” or hand held. When this option is selected, making the connection between terminals 11 & 12 will activate the “load shed” software routine, which will inhibit the operation of either the unit or in the case of twin cylinder units unit or just the 2<sup>nd</sup> cylinder. This will limit the power used during peak supply periods. If this option is selected, the fan interlock, airflow switch and/or high limit hygrostat should be wired into terminals 9 & 10 with the EPO switch if fitted (as per the drawing on the far right). It should be noted that selection of this option will mean that frost protection cannot be utilized.

**Please note that if a display is connected to the unit “DI1 Control Option” must be set to the following:**

- Single cylinder units: “Load shed”.**
- Twin cylinder units: either “Load Shed Cyl 2” or “Load Shed Both”.**

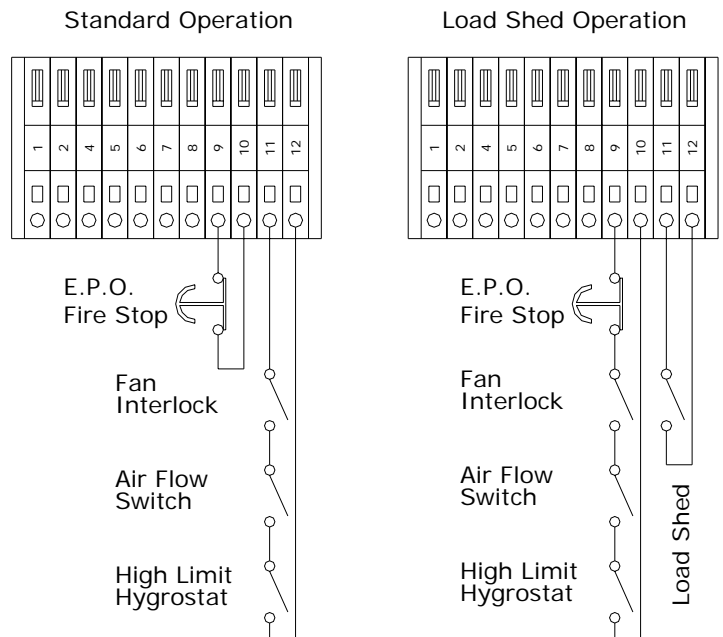

**NB. The total cable length of the network (using the cable recommended by V.H.C.L. – Our part number 8040251) is 500 m and it should be assumed that there is 1 m of cable in each unit of the “system” (including the “master”).**

### 1.5.8 Master/Slave System

For larger duties, VAPANET "Resistive heater" units can be interconnected and arranged to operate from one proportional signal as a Master/Slave system. The system allows up to 10 cylinders to be linked in this way. The slave units will all be "on / off" units. The master unit, to which the proportional signal is connected, can be "on / off" but will preferably be a "proportional" unit.

To "configure" a system, ensure that the control signal is zero [disconnect the control signal, or switch the units off at the front panel switch]. Press and hold the service pin on the master control PCB, until the user LED's flash amber, release and check that the LEDs flash red/amber/green, if not repeat the procedure. Then press the service pin on each of the slave control PCB's in the order that they are required to operate, the slave user LED1 will flash Green/amber until it is configured, once the light goes out [or flashes red/off], proceed to the next slave. If units of different capacity are used, ensure that the master is equal to or greater than the capacity of the slaves, and that the largest capacity slaves come on before the smaller capacity units]. Once this process is complete, confirm the fact by pressing the service pin on the master PCB until user LED2 goes green [this step is not necessary if all nine slave cylinders are configured].

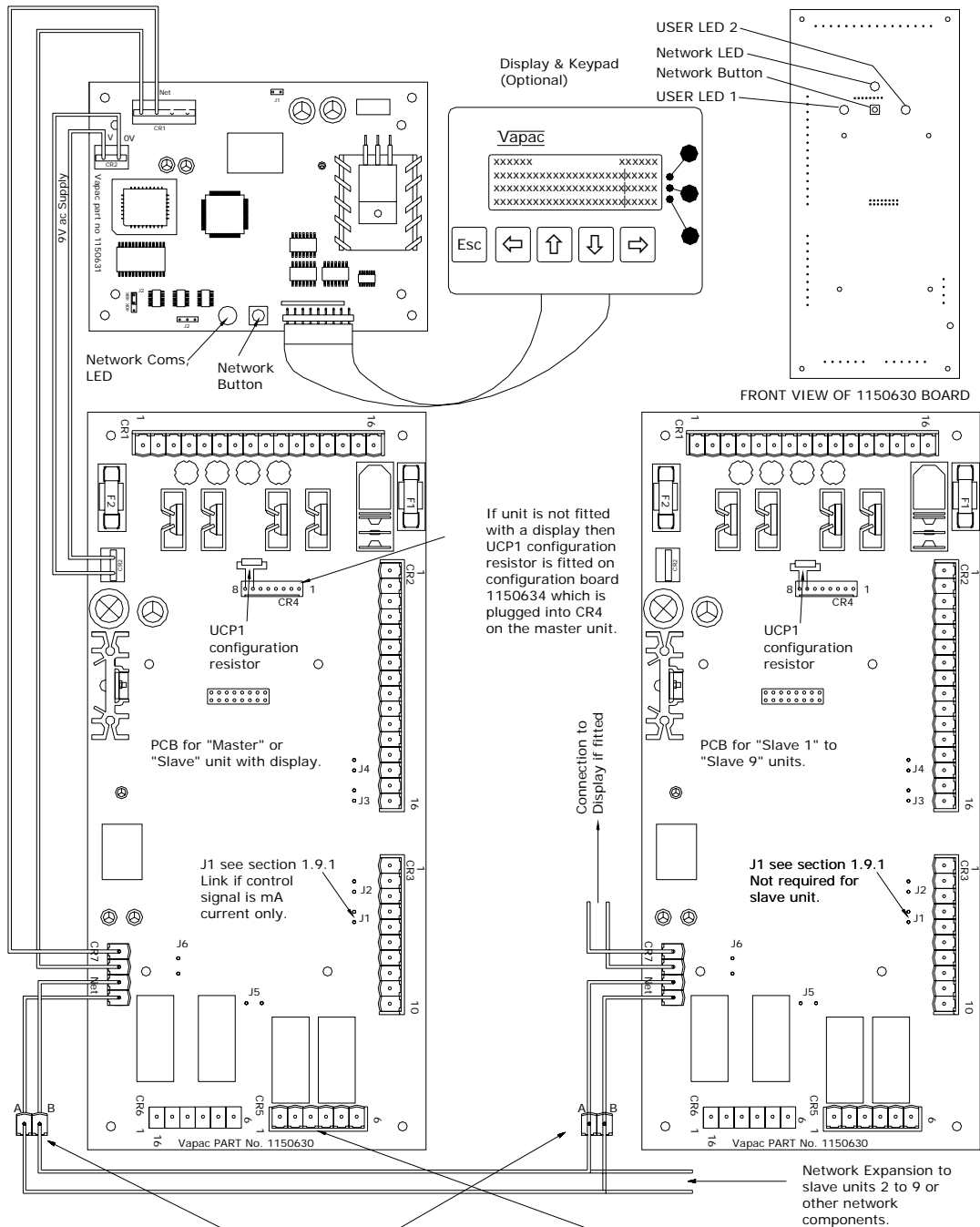

Remote Indications  
 CR6 gives the following remote indications as Volt-free contacts:  
 Terminal 547 - Unit Run (normally open)  
 Terminal 546 - Unit Run (normally closed)  
 Terminal 545 - Unit Run (Common)  
 Terminal 544 - Unit Alarm (normally open)  
 Terminal 543 - Unit Alarm (normally closed)  
 Terminal 542 - Unit Alarm (Common)

**2.0 Start-Up / Operation**

**2.0.1 Start-up check list**

- a) **Water supply and Drain Connections:** these should be connected as indicated under Plumbing and in accordance with the relevant local regulations. An isolation valve should be adjacent to the unit. The connecting metal plumbing must be grounded close to the unit.
- b) **Steam Line:** This must be connected according to the installation instructions with adequate slope and support.
- c) **Power supply:** Wiring to the Vapanet unit Should be by a qualified electrician and comply with the relevant regulations using appropriately sized cable and cable glands, with disconnect and fuses to suit the maximum fuse rating of the unit at the supply Voltage. The disconnect/fuses should be adjacent to the unit or within easy reach and readily accessible.
- d) **Control Connections:** Ensure the control signal and security circuit are correctly connected according to the relevant instructions/diagrams.
- e) **VAPANET 24v / 9V Control Circuit Transformer:** The standard 24V transformer used in the units has primary winding for 200V, 220/240V, 380V, 415V, & 440v 50/60Hz connection derived from the local electrical supply.  
Note: 60Hz connection must be specified with order as 230V 60Hz pump is required.
- f) The maximum output & kW rating of the unit is determined by the number and electrical rating of the heater elements fitted in the cylinder. It is not possible to “de-rate” the unit.
- g) Unit Configuration Plug (U.C.P.). Provides the Vapanet control PCB with information regarding the “system hardware” i.e. the size of the cylinder and whether the unit is an “On/Off” (“LR”) or “Proportional” (“LRP”) model. It is fitted directly onto the control P.C.B. If a display is fitted only one resistor is fitted to the UCP, but if no display is present additional resistors need to be present to provide sufficient information for the unit to operate. If insufficient information is available the unit will remain in the “not\_config” state until the information is supplied. This additional information is provided via the keypad – when the display is fitted.

A brass earth stud is fitted behind the transformer cover to enable this to be easily completed.

See Page 7 / Appendix 1.

See Page 10/11.

See Page 13.

This is fitted below the stainless steel drain tray. To gain access, open the front access door, remove the two M4 screws and remove the transformer cover by sliding it forward.

**Right:** UCP's fitted to Configuration PCB Part number 1150634, as if a display is not fitted to the unit.

Thermistor input from control terminals 1 & 2 (Not shown) are connected to Configuration PCB CR1.

The Jumper plugs (J1) should be used to select the site demand signal type (from the following options: 0-5V; 0-10V; 2-10V; 1-18V; 0-20V; 4-20mA [jumper J1 on main PCB should also be made – see page 13] Pot.; Full O/P; Network or Slave.) and (J2) the site water quality (from the following options: De-min; De-ion; softened, Pot. Low; Pot. Medium; Pot. High).

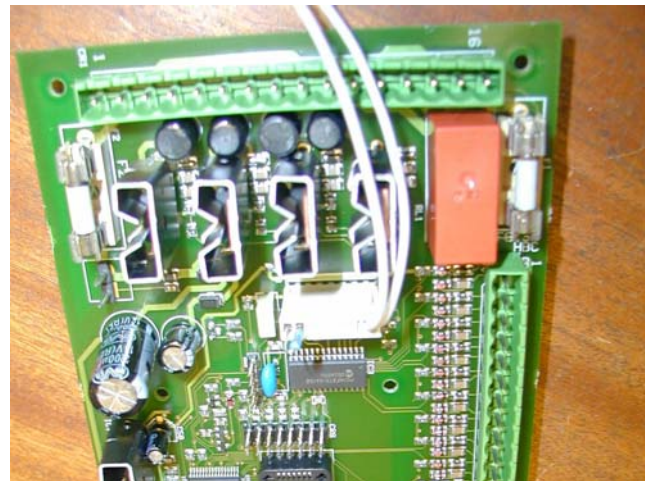

**Above:** UCP1 fitted to Control PCB as if a display is fitted to the unit.

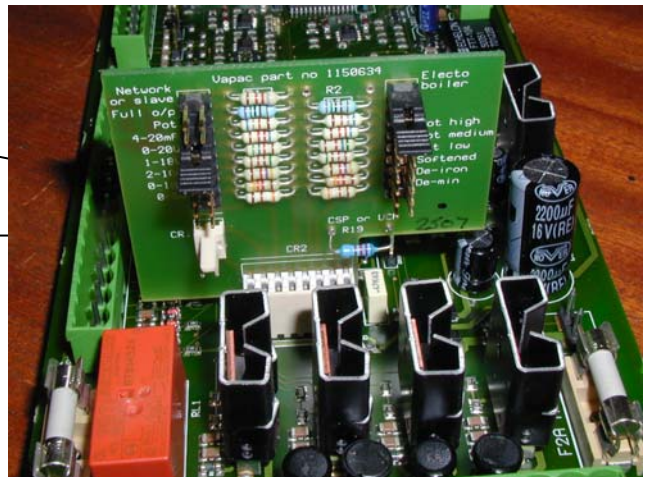

## 2.0.2 Start-Up Instructions

### First check:

- a) **That the transformer connection matches supply Voltage.**
- b) **That the security circuit is closed for unit operation.**

Replace the electrical access panel.

Turn on the water supply to the unit.

Close disconnect/circuit breaker feeding supply to the unit.

Close the On/Off switch.

The display (if fitted) will now show the Set-Up procedure.

Follow the procedure by:

- selecting: the preferred language,
- Attaching the control PCB to the Display.
- nominating: the type/quality of the supply water.
- nominating: the control signal (or Vapac sensor when being used).

When the control signal has been nominated, the Set-Up will be entered into the memory. The Set-Up can then be checked by reading the information menu. If an error has been made, it will be necessary to go back to the Set-up menu. If no display is fitted the information is set using the jumpers on the small resistor PCB 1150634, fitted to CR4 of the control PCB.

## 2.0.3 Commissioning/Start-Up

Once the Set-Up procedure has been completed, the unit is available to operate according to the requirements of the control signal.

When starting with an empty cylinder, the VAPANET programme feeds water in until the water reaches the bottom float switch, when the contactor(s) switch on powering the elements. Thereafter the VAPANET system will continuously monitor and control the conductivity by adjusting the amount of water drained and fed into the cylinder.

## 2.0.4 Features of VAPANET Resistance Heater Unit

The VAPANET system of control is designed to adjust the function to keep the unit operating in the face of changing water quality in the cylinder and changing electrode condition even if, in an adverse operational circumstance, this results in some reduction in output while the situation exists.

### Overtemperature protection.

Should the water supply and the float switch fail, an over temperature cut-out is fitted to the top of the cylinder. If this operates, the contactor will open, removing the power to the elements. This cut out must be manually re-set, by pressing the small button between the electrical connections. **THIS SHOULD ONLY BE DONE ONCE THE CYLINDER HAS BEEN INSPECTED AND THE FAULT(S) RECTIFIED.**

### Foaming protection \*

In particular, the VAPANET is designed to prevent the onset of foaming and to introduce corrective drainage to keep the unit working.

\*Not applicable to units fed with de-ionised/de-mineralised water.

### Automatic switch-off

The VAPANET PCB will stop operating in response to extreme fault conditions identified as:

Drain Fault STOP (no drain function) Feed Fault STOP (water not reaching cylinder) In each case, the display will show the STOP condition and a Help Message, the User LED's on the fascia will indicate the condition see table on page 16. A warning signal will be available for remote indication. The STOP condition of a VAPANET PCB will be cleared via the key pad if a display is fitted or by pressing the reset button on the fascia – the unit should first be powered down completely (while the reason for the condition is diagnosed and rectified). **THIS ACTION SHOULD ONLY BE TAKEN ONCE THE CAUSE OF THE PROBLEM HAS BEEN ASCERTAINED AND RECTIFIED.**

The transformer is fitted below the stainless steel drain tray and is accessible by removing the two M4 machine screws and sliding the cover forwards.

If no security circuit is fitted (i.e. no airflow switch or high humidity override hygrostat is required) terminals 9 & 10 must be linked.

If no display is fitted, the selections are made by fitting jumper plugs to the "Configuration PCB" (Part number 1150634). See page 13.

If no display is fitted the "User LED's" will be the only indication of a "Fault Condition". LED 1 (Left hand) represents cylinder 1 (Left hand when viewed from the front) and LED 2 (Right hand) represents cylinder 2, if fitted.

If a fault condition exists, the LED representing the cylinder which has the fault will glow "Amber" (constant for drain fault / flashing for feed fault). The unit should be powered down at the main Isolator once the reason has been diagnosed, and the problem rectified. When the power is re-applied, the unit will once again display a fault indication. To reset the alarm condition the "fault reset" button should now be pressed (or the "OK" button on the display keypad should be pressed if a display is fitted).

**2.1 Service Advice**

After a pre-determined time an alarm warning – together with an alpha-numeric message – will be displayed, warning that the cylinder should be inspected and cleaned as necessary.

Once this signal has occurred, the following service routine should be undertaken as soon as possible. On completion of the service, the service interval timer will be reset, and there will be an opportunity to adjust the service interval, if the service reveals that the interval was inappropriate for the operating conditions.

**Service Advice Routine**

**2.1.1 Cylinder Inspection.**

(See figs 1 - 4)

- 1 ENSURE THAT THE UNIT IS ISOLATED FROM THE POWER SUPPLY. Then remove the power supply plug from the fixed socket.
- 2 Lift cylinder until the bottom (ø 22 mm) spigot is clear of the feed/drain manifold. *NB it may be necessary to remove the steam hose from the cylinder, (top) steam outlet spigot, to achieve this.*
- 3 Bring the base of the cylinder forward then allow the cylinder to rest on the cylinder support ring, then remove the cylinder.
- 4 Undo the securing latches, remove the clamping ring and lower cylinder casing.
- 5 Empty any loose scale from the lower casing, and clean as necessary.
- 6 Inspect the elements, for excessive scale build-up or damage, and clean/ replace as required - *Should it be necessary to replace elements, ensure that they are replaced with the same type and power. Please also ensure that the integral cables are re-connected exactly as the original. When disconnecting an element, please note the points of disconnection.*
- 7 With the lower cylinder casing removed, and access to the float chamber improved remove the float chamber by unclipping it from the back panel and open the housing by removing the two plastic clips (use a screwdriver to lever these off) & pulling it apart (see fig 4).
- 8 Inspect the float switches, and clean/de-scale as necessary. A build up of scale can prevent correct operation of the switches, which - in turn - will lead to operational problems with the unit.
- 9 Re-assemble cylinder by repeating the above steps in reverse. To ensure that the cylinder seals correctly, ensure that the first four clamps that are tightened, are those at the four quadrants. I.e. tighten one clamp then tighten the one diametrically opposite. Then tighten one at approximately 90° to them and then tighten the one diametrically opposite. Finally, tighten any remaining clamps.

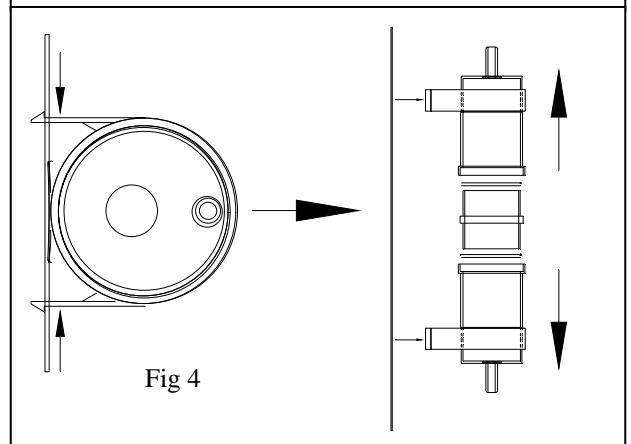
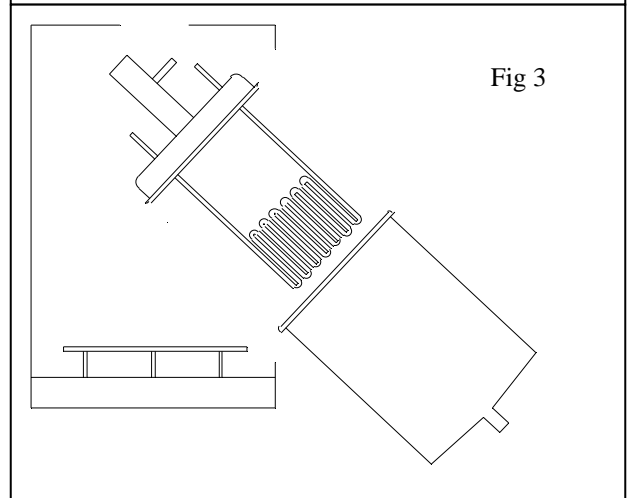
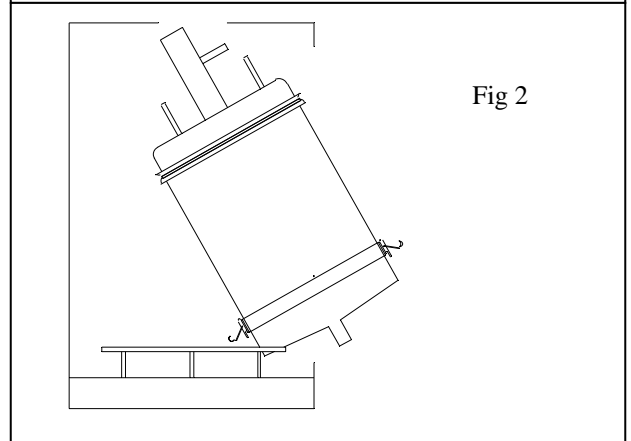
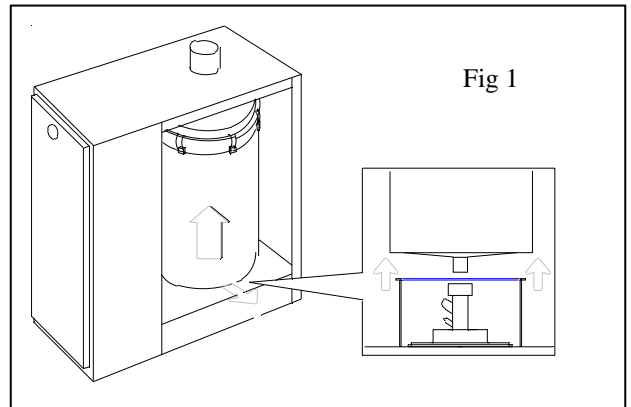

**Other Maintenance:**

- Should only be carried out by a qualified electrician.
- The steam cylinder should be drained prior to carrying out any maintenance in the steam section – This must be done prior to isolating the electrical supply, i.e. before removing the front access panel.
- The unit should be isolated from the electrical supply before any cover or access panel is removed.

**2.2 Service and Maintenance**

As the operation of the Vapac is entirely automatic, it normally requires no attention on a day-to-day basis. General cleaning and maintenance of the component parts of the Vapac are recommended at intervals of about one year, but this is largely dependent upon the frequency of its use and the quality of the water supply. Where the Vapac is part of an air-conditioning system being serviced regularly, the Vapac should be inspected at the same time.

**2.2.1 Feed Valve with Strainer**

The nylon bodied solenoid valve incorporates a small nylon strainer which is a push fit in the 3/4" inlet of the valve. With a new plumbing installation, residual loose solid material in the pipework could partially block the strainer after start-up. If for this or any other reason a restriction of the water flow is suspected (outside of supply pressure considerations), it would be possible to clean the strainer as follows:-

Turn off the water supply to the Unit.  
Undo the nylon nut connecting the flexible connection to the valve inlet.

The strainer can be removed using 'long-nosed' pliers to grip the centre flange provided on the strainer for this purpose. Withdraw the strainer. Wash and replace it. Reconnect and turn on water supply. Reconnect electrical supply to allow unit to operate.

*Note: Always replace the strainer after cleaning as it is required to prevent material lodging in the valve seat or blocking the small flow control restrictor which is fitted in the valve.*

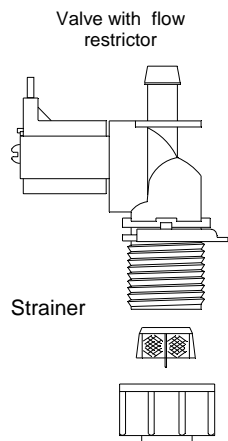

3/4 Nylon nut with washer as part of flexible connector

**Steam and Condensate Hoses**

The hoses used with and in the Vapac should be inspected at the normal service visits as part of normal maintenance. At the first signs of deterioration, a hose should be removed and replaced.

**2.2.2 Drain Pump**

The pump The pump is a sealed unit and should not be dismantled. Instructions for removal / replacement are as follows

1) Place a bucket below the pump, to catch any water remaining in the housing or pipework.

2) Remove the two screws holding the pump cover & lift clear.

3) Undo the three screws holding the pump body to the feed & drain manifold, and remove it - any water trapped in the pump will be released at this point.

4) Fit the replacement pump by following the above steps in reverse order. Ensuring that the O-ring surrounding the impeller Housing is correctly seated, and That it mates correctly with the Feed / drain.

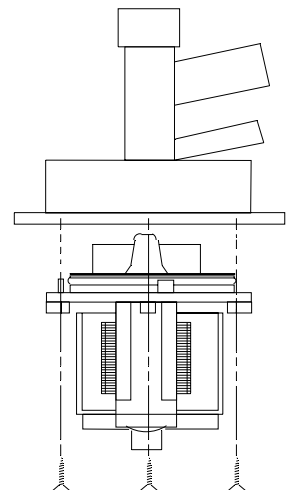
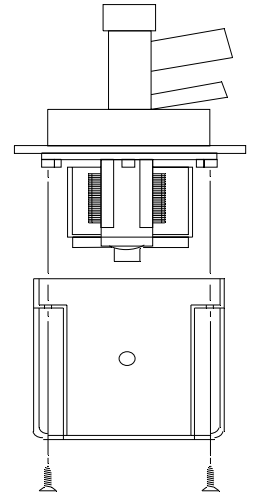

### 3.0 Location of Indicators and Controls

#### 3.1 Positioning of Indicators and controls on Vapac® Vapanet® LR Units.

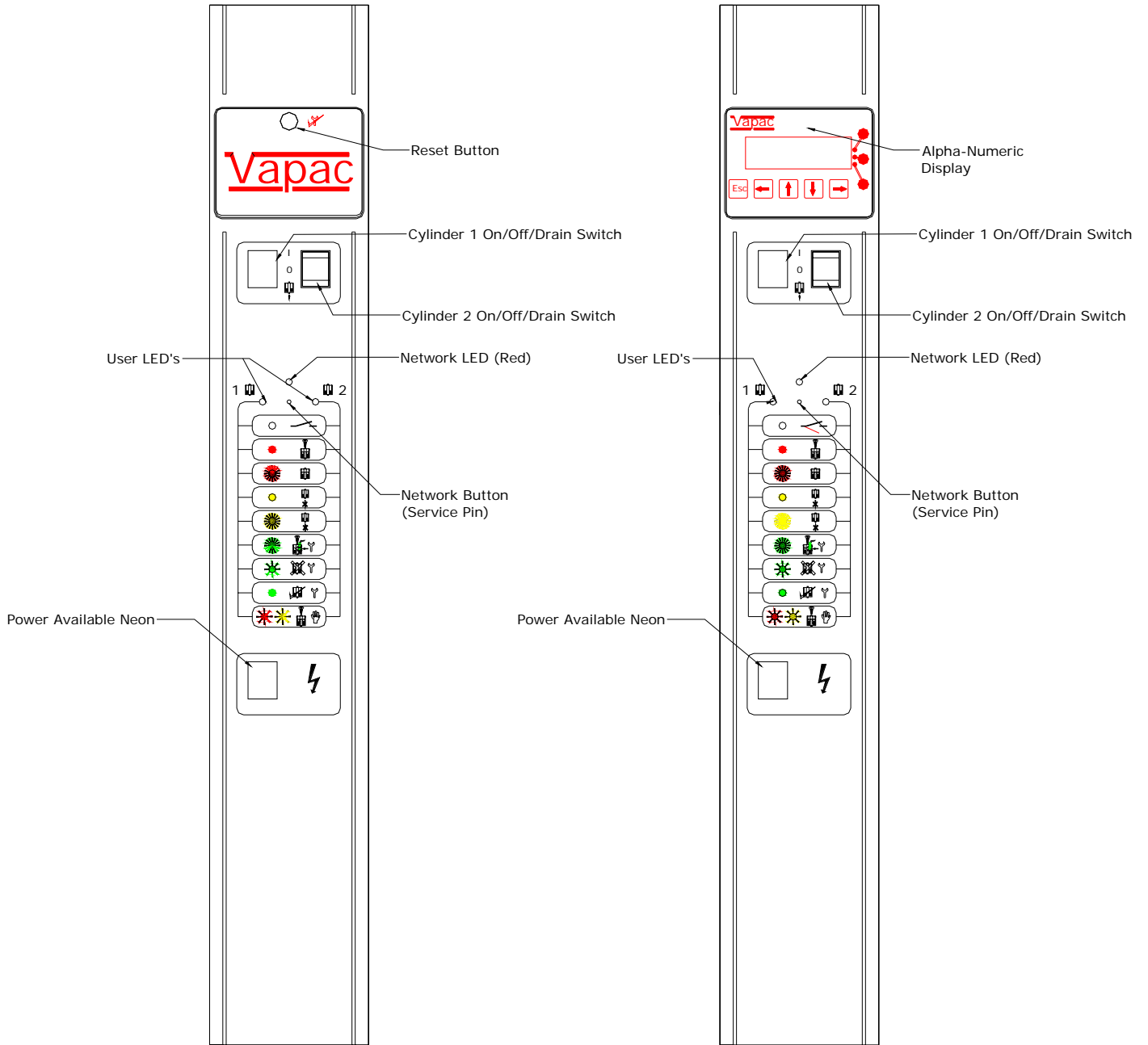

## 3.2 Initial Set-up

### User LEDs

During the initialisation process the User LEDs can be in one of the following states

User LED State		Description
1	RED Flashing 2 second period	Unit initialising. If remains in this state, then unit does not a valid UCP1 fitted.
2	RED/AMBER Flashing 2 second period	<b>UCP1 valid.</b> For units fitted with a configuration board, the UCP2 and/or UCP3 are not being detected.
3	RED/GREEN Flashing 2 second period	<b>UCP1 valid.</b> For units fitted with a display, the unit requires site set-up. This state does not occur if the unit is fitted with a configuration board.
4	User LED 1 - RED/AMBER/GREEN User LED 2 – OFF	Unit in configuration set-up mode, as instructed from the attached display node.
5	User LED 1 & LED 2 - RED/AMBER/GREEN	Invalid configuration UCP2 is not valid.

**Prior to the start of the initialisation process, the LEDs will flash Green, Red, Amber repeatedly for 10 seconds to check that the LEDs are operation correctly.**

#### Remedy:

- 1 Check that UCP1 is fitted to plug fitted to CR4 pins 7 & 8 for units with Alpha-numeric display or fitted to configuration PCB part number 1150634, which is fitted to CR4 if no display is fitted (see section 1.5.3 of manual for more details). Ensure that good electrical contact is made in each case.
- 2 Check that the jumpers J1 & J2 on the configuration PCB are correctly fitted, to select the site water quality and site control signal (see section 1.5.3 of the manual).
- 3 Enter "Set-up unit", enter the "control signal" type and "site voltage", see Alpha-numeric display module operating manual.
- 4 Once the unit has been "set-up" press ok at the prompt "Apply changes are you sure \*?\*" when the unit will exit this state.
- 5 Check that the jumper J2 (on the configuration PCB) is correctly fitted, selecting the correct site water type (see section 1.3.1 of the "Installation, Operation & Maintenance Manual").

### 3.3 Normal Run / Standby / Start-up – No User Intervention Required

Once the unit has initialised User LED 1 refers to cylinder 1, while User LED 2 refers to Cylinder 2. For combinations of LED 1 and LED 2 being off, RED or RED Flashing refer to following table.

User LED 1		User LED 2	Description																											
1	OFF	OFF	Cylinder 1 and Cylinder 2 (if fitted) in shutdown. Or Cylinder 1 in standby and Cylinder 2 in shutdown.																											
2	OFF	RED Flashing 1 second period	Cylinder 1 and Cylinder 2 (if fitted) in standby																											
3	RED Flashing Variable Period or ON	OFF	<p>Cylinder 1 Online. Cylinder 2 (if fitted) in standby</p> <p>The variable period is determined by the demand signal for cylinder 1 as follows,</p> <table border="0"> <thead> <tr> <th>Cylinder 1 demand</th> <th>LED ON RED</th> <th>LED OFF</th> </tr> </thead> <tbody> <tr> <td>&lt;12.5%</td> <td>0.5 seconds</td> <td>3.5 seconds</td> </tr> <tr> <td>&lt;25%</td> <td>1.0 seconds</td> <td>3.0 seconds</td> </tr> <tr> <td>&lt;37.5%</td> <td>1.5 seconds</td> <td>2.5 seconds</td> </tr> <tr> <td>&lt;50%</td> <td>2.0 seconds</td> <td>2.0 seconds</td> </tr> <tr> <td>&lt;62.5%</td> <td>2.5 seconds</td> <td>1.5 seconds</td> </tr> <tr> <td>&lt;75%</td> <td>3.0 seconds</td> <td>1.0 seconds</td> </tr> <tr> <td>&lt;87.5%</td> <td>3.5 seconds</td> <td>0.5 seconds</td> </tr> <tr> <td>&gt;=87.5%</td> <td></td> <td>ON RED Continually</td> </tr> </tbody> </table>	Cylinder 1 demand	LED ON RED	LED OFF	<12.5%	0.5 seconds	3.5 seconds	<25%	1.0 seconds	3.0 seconds	<37.5%	1.5 seconds	2.5 seconds	<50%	2.0 seconds	2.0 seconds	<62.5%	2.5 seconds	1.5 seconds	<75%	3.0 seconds	1.0 seconds	<87.5%	3.5 seconds	0.5 seconds	>=87.5%		ON RED Continually
Cylinder 1 demand	LED ON RED	LED OFF																												
<12.5%	0.5 seconds	3.5 seconds																												
<25%	1.0 seconds	3.0 seconds																												
<37.5%	1.5 seconds	2.5 seconds																												
<50%	2.0 seconds	2.0 seconds																												
<62.5%	2.5 seconds	1.5 seconds																												
<75%	3.0 seconds	1.0 seconds																												
<87.5%	3.5 seconds	0.5 seconds																												
>=87.5%		ON RED Continually																												
4	Any	RED	Cylinder 2 Online																											

**The above are purely indications of the current state of the unit, and require no action from the operator. When the state changes the indication will automatically change.**

### 3.4 Fault / Service Indications – Requiring Operator Intervention.

User LED State		Description
1	AMBER	Drain Fault
2	AMBER Flashing 1 second period	Feed Fault
3	AMBER Flashing 2 second period	Over temperature Fault
4	GREEN/AMBER Flashing 1 second period	Float Switch Fault
5	GREEN Flashing 1 second period	Service Interval expired or low output.
6	GREEN Flashing 2 second period	Periodic Flush/Periodic Drain/Manual Drain/Auto Flush in progress
7	GREEN	Periodic Drain/Periodic Flush/Manual Drain completed.
8	RED/AMBER 1 second period	Constant Output Active/Full Output via UCP3 (Master cylinder only)

- 1 & 2     **Fault stop:** Once the problem has been cleared the fault can be re-set by one of the following procedures.
- i) **Units fitted with an Alpha-numeric display:** Power the unit right off, using the local isolator (not the unit on/off switch), waiting ten seconds, then re-applying power. When the message “Cylinder x drain fault” is once again displayed press the o.k. button, and the unit will revert back to it’s operational state.
  - ii) **Units not fitted with a display:** Power the unit right off, using the local isolator (not the unit on/off switch), waiting ten seconds, then re-applying power. When the constant amber “drain fault” indication is showing, press the unit “fault reset” button, which is located on the fascia above the “Vapac” Logo.
- 2           **High Temperature Fault:** When the cylinder has cooled down, investigate the reason for the “over temperature” condition, paying particular attention to the feed water supply. Manually drain the cylinder, and carry out a cylinder inspection (see section 2.1.1 of the “Installation, Operation & Maintenance manual”). When complete, reset the high temperature cut-out on top of the cylinder and re-start the unit.
- 4           **Float Switch Fault:** Will be seen if the top float switch is made, but the lower switch is open. If seen the float switch and associated wiring should be inspected, cleaned and/or replaced as required.
- 5           **Service Interval Expired:** Will be seen if the unit has run for a period exceeding the service interval, which will depend on the quality of the site water supply (see table below).

Water Type	Service Interval Hours
De-min / De-ionised	5000
Softened	2500
Pot. Low	2500
Pot. Med	1000
Pot. High	500

**If this indication is seen the cylinder should be inspected as soon as possible**

If it not convenient to carry out this inspection immediately it is possible to postpone it for a short time.

#### 3.4.1 To Postpone the Service:

**Press the reset button once:** The appropriate cylinder LED will change to constant “amber” and the external alarm will be reset, allowing the unit to continue to run without an external alarm for 168 hours run time.

**When the alarm is repeated, it should be serviced immediately – and not postponed further.**

#### 3.4.2 To Service the unit:

**Press the reset button:**

This will cause the appropriate LED to change to constant “amber”, the external alarm to be reset.

**Press the service button again: (this should be within ten seconds of the first push).**

This will cause a “service routine” to be implemented. Once this is complete,

**Isolate the electrical supply:**

**Inspect the cylinder:** As described in the maintenance section of the operating and maintenance manual.

**Clean the cylinder:** As described in the maintenance section of the operating and maintenance manual.

**Power up the unit:**

**Press the reset button:**

This will cause the appropriate cylinder LED will change to constant “amber” and the external alarm will be reset, allowing the unit to continue to run without an external alarm for a further 168 run hours..

**Press the reset button again: (this should be within ten seconds of the first push).**

This will reset all the relevant timers including the hours run timer.

**NB if the button is not pressed a second time then the alarm will only be postponed, and will quickly return.**

5 **Event in Progress:** This is a transitional state while the unit is actually performing a particular routine. The LED indication is for information only and requires no user intervention.

6 **Event Completed:** If one of the above conditions have been implemented, when it has been completed, the unit by default will continue to run, however it is possible to change this to “stop” (via a display either fitted or hand held) if this is the case this condition will be exhibited, and the unit will not run until the condition has been reset, by either:

i) **Units fitted with an Alpha-numeric display:** Power the unit right off, using the local isolator (not the unit on/off switch), waiting ten seconds, then re-applying power. When the message “event complete” is once again displayed press the o.k. button, and the unit will revert back to it’s operational state.

ii) **Units not fitted with a display:** Power the unit right off, using the local isolator (not the unit on/off switch), waiting ten seconds, then re-applying power. When the constant green “event complete” indication is showing, press the unit “fault reset” button, which is located on the fascia above the “Vapac” Logo.

7 **Constant output:**

i) **Units fitted with an Alpha-numeric display:** This is another transitional state, and once the “constant output period” has expired, the unit will revert to normal “controlled” operation. The LED indication will automatically revert to the cylinder’s “current state”.

ii) **Units not fitted with a display:** Once the testing of the unit is complete, the jumper J1 on the configuration PCB should be removed from the full output position and returned to its normal operating position.

### 3.5 Other Options

All selectable via a display (either Hard Wired or Hand held)

#### Feed With Drain

Used to lower the temperature of the drain water.

#### Frost Protection

When this is activated the unit will operate, at a preset demand level, if the temperature surrounding the unit falls below a preset level, to prevent the pipework from freezing.

It is enabled by setting "frost demand" (via keypad/display) to >0 (it is disabled by setting "frost demand" to 0). However the unit will not operate unless "frost demand" is set above the unit minimum demand level. Minimum demand level for LE units is 21% and for LEP units it is 10%. Frost demand is fully adjustable between 0 & 50%.

#### Timed Drain down.

Used to drain all the water from the cylinder if the unit remains on standby for longer than a preset (but adjustable) time period.

For information on setting these options please see the display manual.

### 3.6 Use with LRO unit.

For information on setting up a system with a Vapanet Reverse Osmosis unit please see the documentation supplied with the LRO unit.

The following light sequences may also appear on the LR unit fascia if an LRO unit is supplying the feed water supply:-

#### User LED 1 Sequence:

Amber (off) Green (off):

Amber (off) Amber (off) Green

Amber (off) Amber (off) Amber (off) Green

#### Meaning:

LRO in "Shutdown" Mode (Switched off or EPO/security circuit open)

LRO unit not responding. (LR unit "Fault" relay will make).

LRO unit in "Fault" condition. (LR unit "Fault" relay will make).

## 4.0 Trouble-shooting Check List

<b>Preliminary</b>	- <b>Use manual drain option to check pump operation</b>
<b>Symptom</b>	<i>Check/Cause/Remedy</i>
Power-On Neon – Off	- Check main power is connected and switched on.
Symbol-LED – Off	- Check power supply fuses.
Display - Blank	
Power-On Neon – On	- Check if security circuit is open circuit
Symbol-LED – On	- Check 24V 6.3A fuse mounted at top of Microvap controller PCB 1150630
Display - Blank	

### Automatic STOP – Feed Fault indicated on the Display.

Possibilities	Checks
Water is not connected	- Check water stop valve is open
Water connected but not reaching cylinder.	- Check internal Vapac hose connections for a leak.
Water in cylinder and overflowing.	- Check float switch operation

### Automatic Stop – Drain Fault indicated on the display.

Possibilities	Checks
Drain pump function impaired	- If pump will not function, empty cylinder by disconnecting at the tundish fill-cup the water supply hose to the cylinder and draining the water into a bucket. Remove, dismantle and clean pump housing / Replace pump if required.
Float switch failure	- Check float switch operation
Cylinder O/Let Blocked	- Check & unblock

### Unit On-Line but inadequate or no steam production.

Possibilities	Checks
Contactors not made	- Contactor coil, Float switches, Control PCB.
MCB's tripped	- Cylinder Inspection, inspect elements, and float switch operation.
SSR's not switching	- SSR Check as described below,

#### Important

#### Specialised check of the Solid State Relay

#### Equipment needed

- The following check should be carried out by a competent electrician**
- An AC Voltmeter, multi-meter set to full AC line voltage or suitable voltage test instrument.

#### Procedure

- Remove access panels from both the steam cylinder and electrical compartments
- Ensure that the humidifier has an operational level of water in the cylinder. Switch unit on and check that the display indicates "Vapac on line".
- Apply the voltmeter, set to the full line Voltage, across the output terminals of the SSR being tested (i.e. the two terminals carrying the cabling to the elements).

#### Correct Voltmeter Response – oscillating between full and near zero Voltage.

If Voltmeter reads a constant near zero Volts, Check:

- a) That the unit is not feeding water – if it is, wait until the feed valve closes and then re-check. (reason the SSR will hold closed while the feed valve is open).
- b) That the control PCB is giving the correct pulsed D.C. signal (approx 5V D.C.) to the SSR control input terminals.

#### SSR Replacement

A faulty SSR should be replaced with an SSR of the same (or higher) Voltage and amperage rating. Disconnect the unit from the electrical supply. Disconnect the SSR and undo the mounting screws. The SSR is bedded in thermal compound to assist heat transfer – it is important that this is cleaned off, and a layer fresh compound placed under the replacement SSR. When it is secured in position. Reconnect the SSR, reconnect the electrical supply and check the SSR function as above before replacing the access panels.

**Note: Use proprietary thread locking compound on the line voltage**

5.0 Wiring Diagram

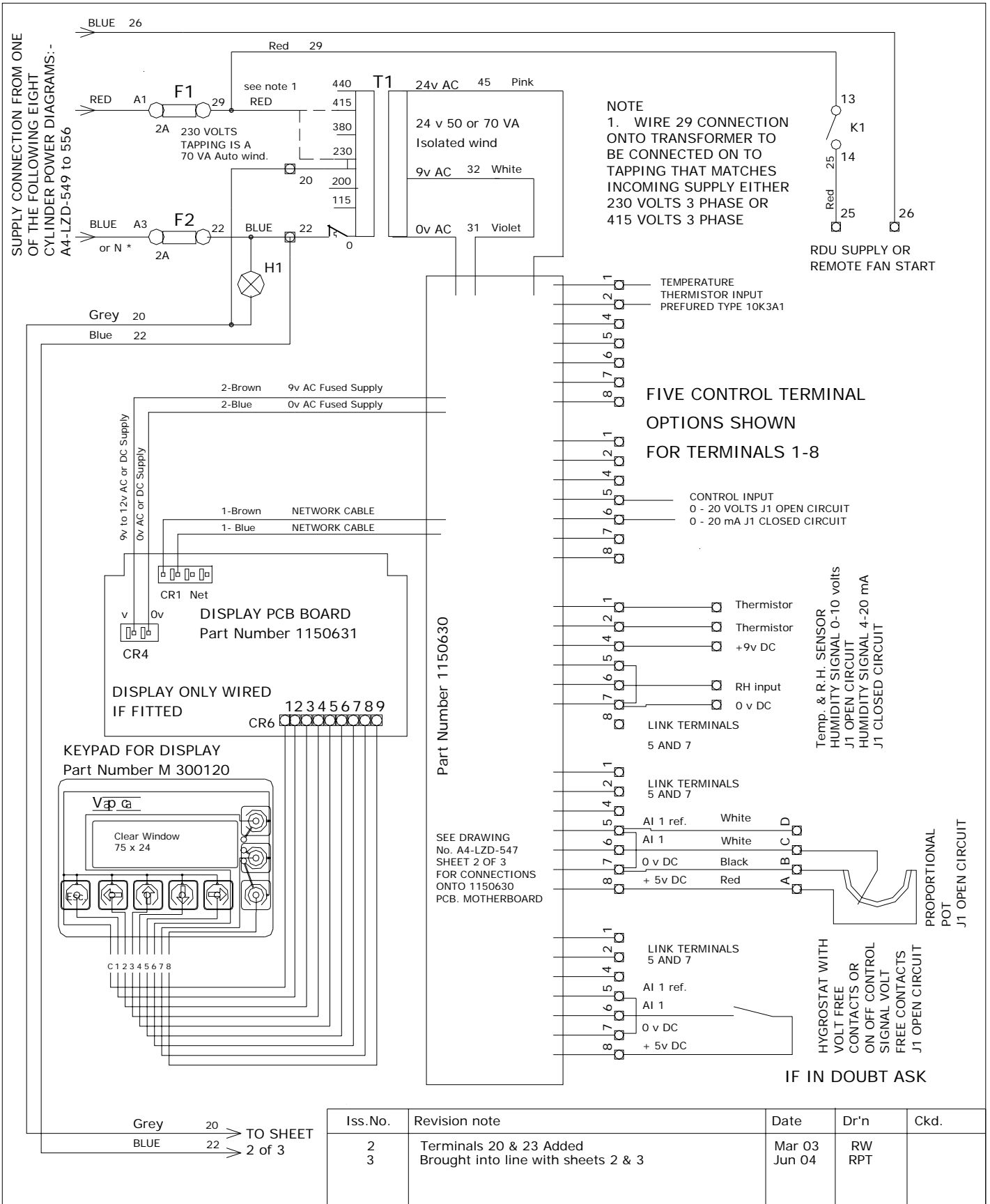

Vapac Humidity Control Ltd.  
Fircroft Way, Edenbridge,  
KENT, TN8 6EZ. ENGLAND.  
PHONE +44(0)1732 863447

**TITLE:** VAPAC SINGLE CYLINDER RESISTIVE HUMIDIFIER CONTROL FITTED WITH VAPAC 1150630 motherboard Main supply control transformer and customer control signal inputs

**DATE :** FEB 2002  
**ITEM REF:** LR  
**SCALE :** N.T.S.  
**SHEET No.** 1 OF 3  
**ISSUE :** 3

**DRAWING No.:** A4-LZD547





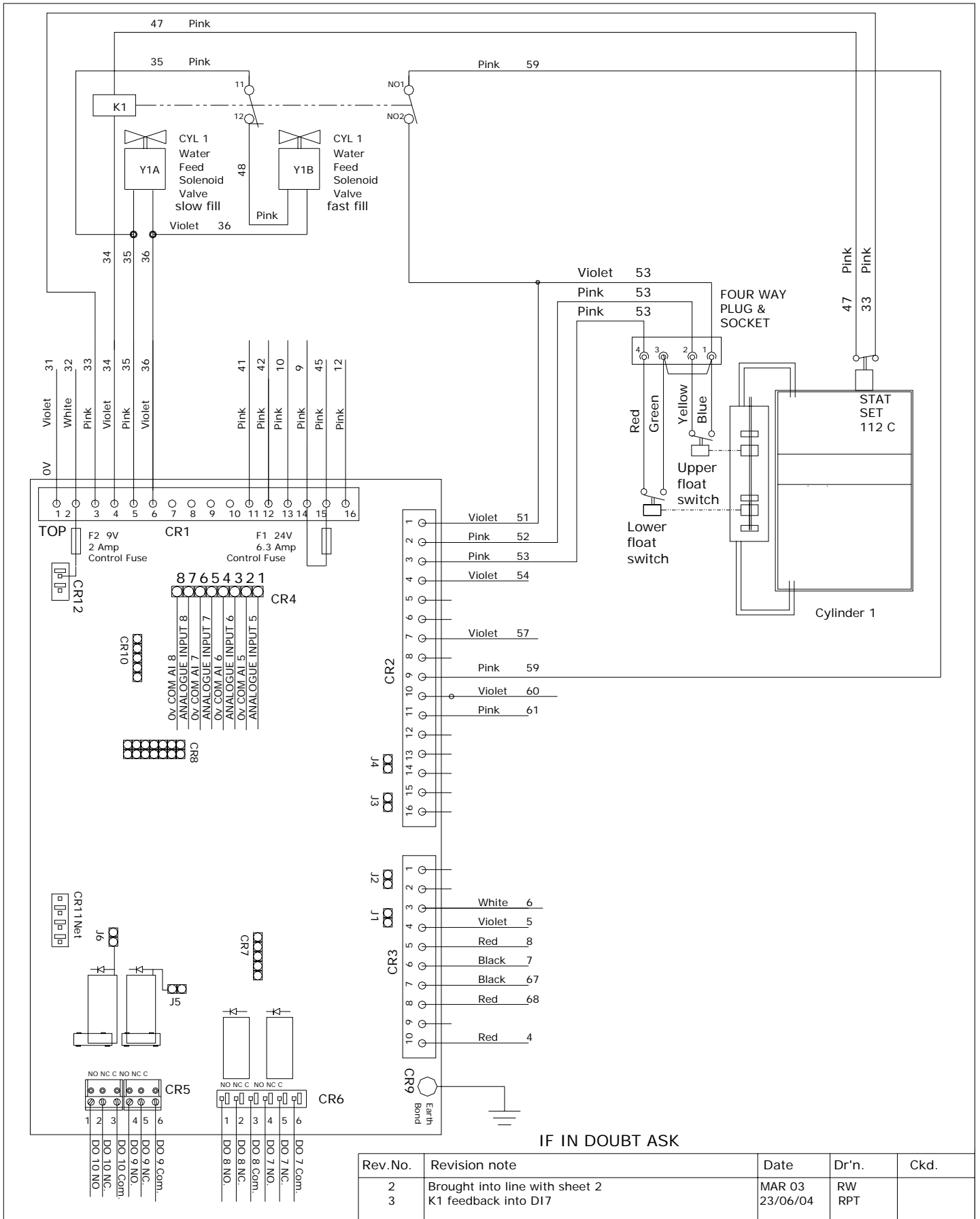

**Vapac Humidity Control Ltd.**  
 Fircroft Way, Edenbridge,  
 KENT, TN8 6EZ. ENGLAND.  
 PHONE +44(0)1732 863447

**TITLE:** VAPAC SINGLE CYLINDER RESISTIVE HUMIDIFIER CONTROL FITTED WITH VAPAC 1150630 motherboard  
 Connections to feed valves, float switches & high temperature stats.

**DRAWING No.:** A4-LZD 547

**DATE :** FEB 2002  
**ITEM REF:** LR  
**SCALE :** N.T.S.  
**SHEET No.** 3 OF 3  
**ISSUE :** 3



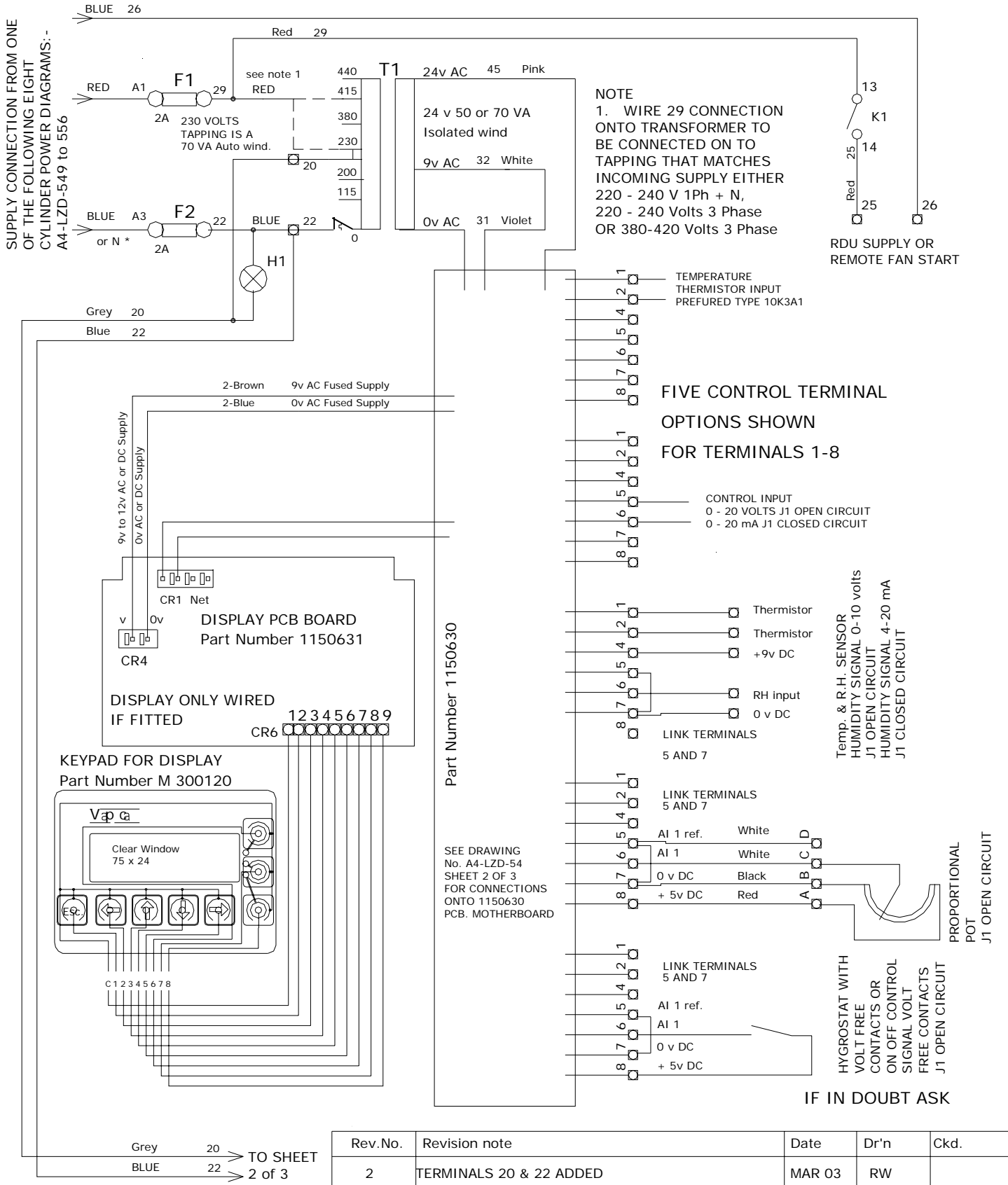

Rev.No.	Revision note	Date	Dr'n	Ckd.
2	TERMINALS 20 & 22 ADDED	MAR 03	RW	
3	Brought into line with sheets 2 & 3	JUN 04	RPT	

**Vapac Humidity Control Ltd.**  
 Fircroft Way, Edenbridge,  
 KENT, TN8 6EZ. ENGLAND.  
 PHONE +44(0)1732 863447

**TITLE:** VAPAC TWIN CYLINDER RESISTIVE HUMIDIFIER CONTROL FITTED WITH VAPAC 1150630 motherboard Main supply control transformer and customer control signal inputs

**DRAWING No.:** A4-LZD-548

**DATE :** FEB 2002  
**ITEM REF:** LR  
**SCALE :** N.T.S.  
**SHEET No.** 1 OF 3  
**ISSUE :** 3



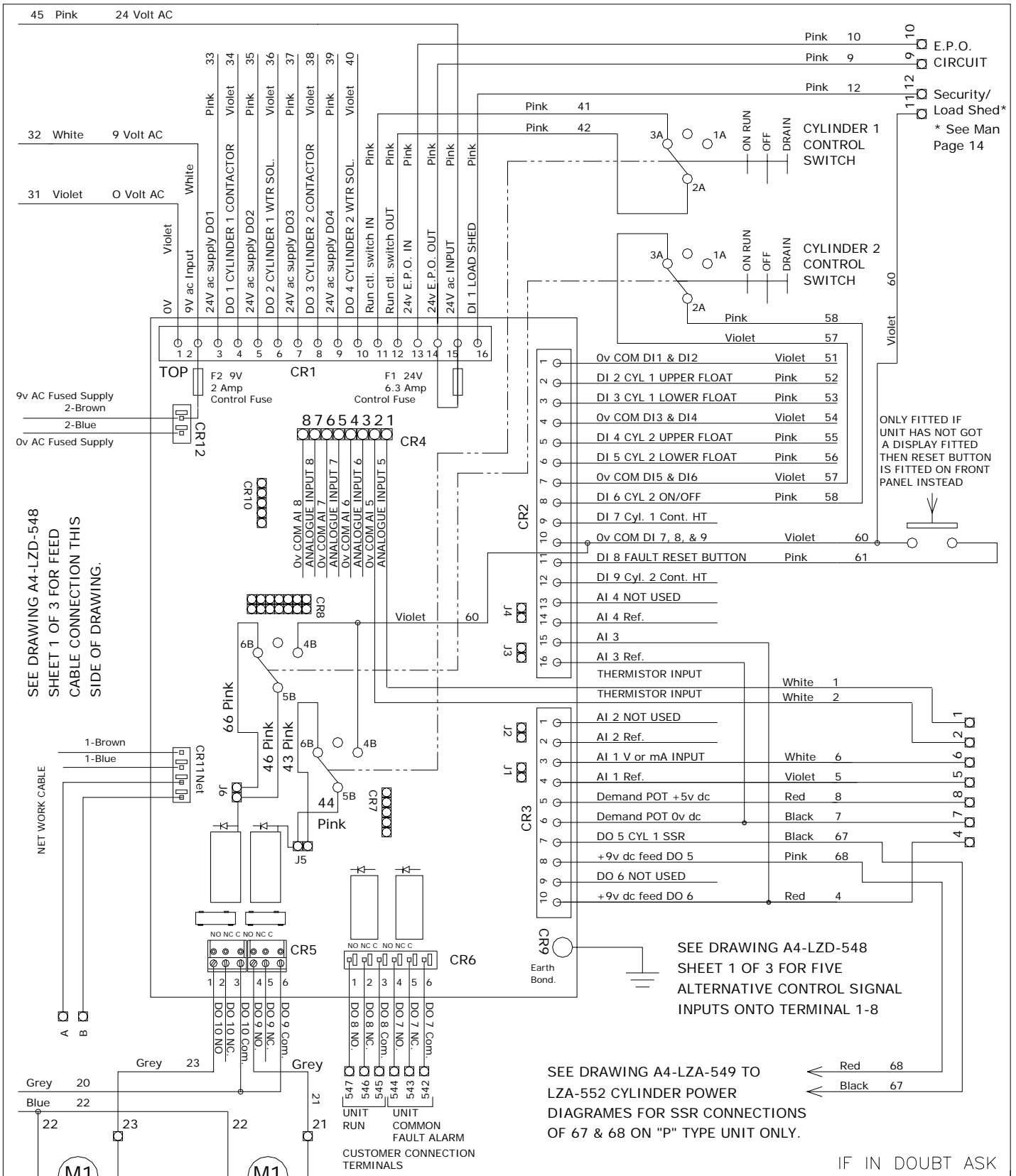

SEE DRAWING A4-LZD-548 SHEET 1 OF 3 FOR FEED CABLE CONNECTION THIS SIDE OF DRAWING.

NET WORK CABLE

CYLINDER 2 DRAIN PUMP 240 V

CYLINDER 1 DRAIN PUMP 240 V

Iss.No.	Revision note	Date	Dr'n.	Ckd.
2	TERMINALS ADDED 542 - 547 & A,B	MAR 03	RW	
3	DI 7 & DI 9 K1 & K2 feedback added	JUN 04	RPT	

IF IN DOUBT ASK

Vapac Humidity Control Ltd.  
 Fircroft Way, Edenbridge,  
 KENT, TN8 6EZ. ENGLAND.  
 PHONE +44(0)1732 863447

TITLE: VAPAC TWIN CYLINDER RESISTIVE HUMIDIFIER CONTROL FITTED WITH VAPAC 1150630 motherboard control input for temp. and RH sensor or control pot  
 DRAWING No.: A4-LZD548

DATE : FEB 2002  
 ITEM REF: LR  
 SCALE : N.T.S.  
 SHEET No. 2 OF 3  
 ISSUE : 3



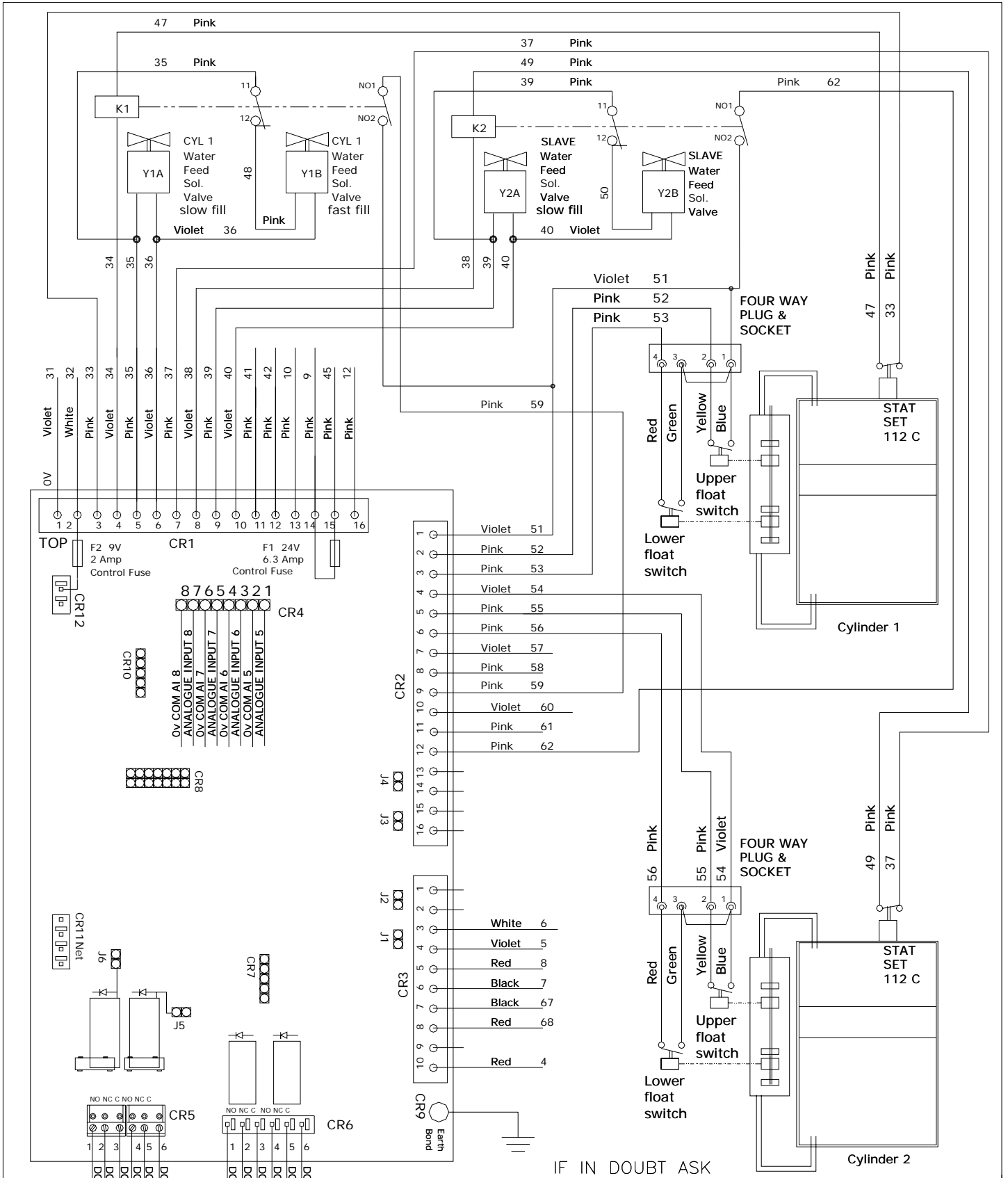

Rev.No.	Revision note	Date	Dr'n.	Ckd.
2	Brought into line with sheet 2	Mar 03	RW	
3	K1 & K2 feedback into DI 7 & DI 9 Added	Jun 04	RPT	

**Vapac** Humidity Control Ltd.  
 Fircroft Way, Edenbridge,  
 KENT, TN8 6EZ. ENGLAND.  
 PHONE +44(0)1732 863447

TITLE: VAPAC TWIN CYLINDER RESISTIVE HUMIDIFIER CONTROL FITTED WITH VAPAC 1150630 motherboard control input for temp. and RH sensor or control pot  
 DRAWING No.: A4-LZD548

DATE : FEB 2002  
 ITEM REF: LR  
 SCALE : N.T.S.  
 SHEET No. 3 OF 3  
 ISSUE : 3



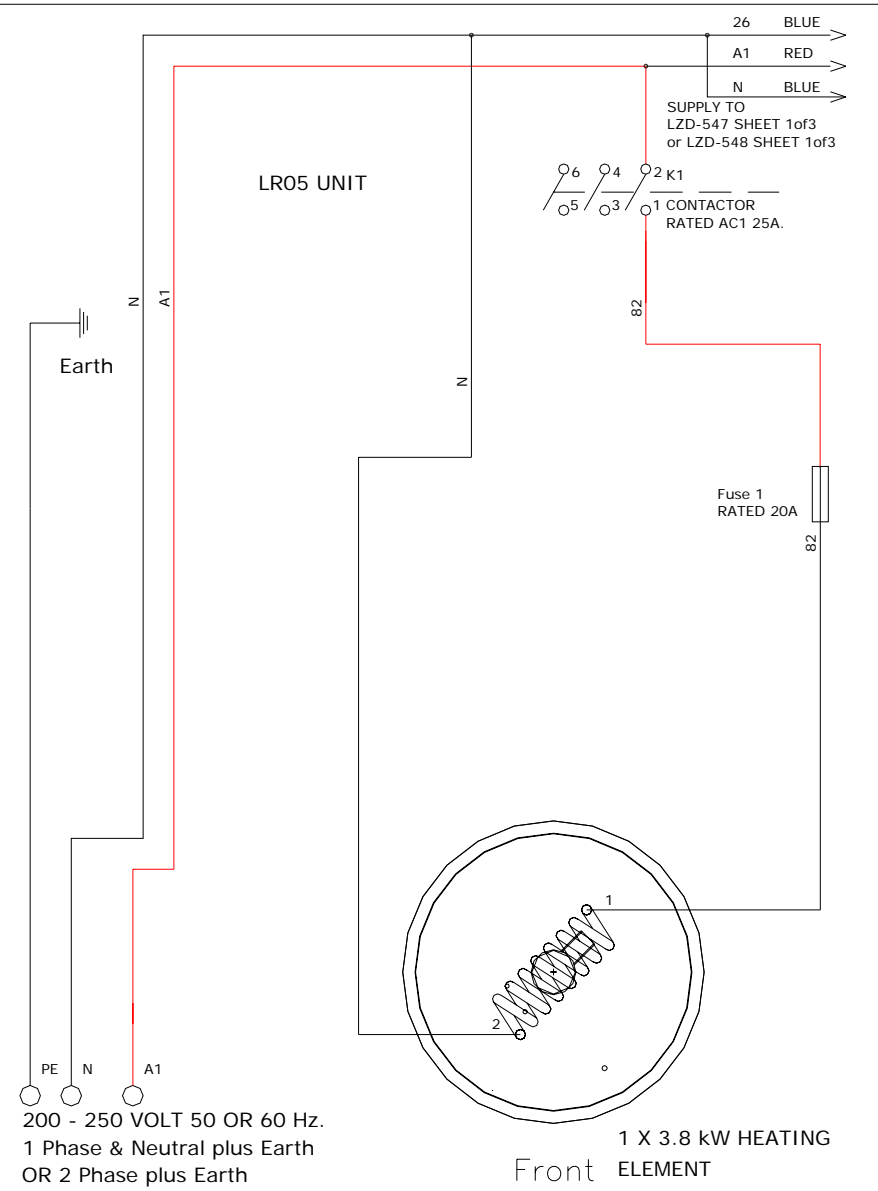
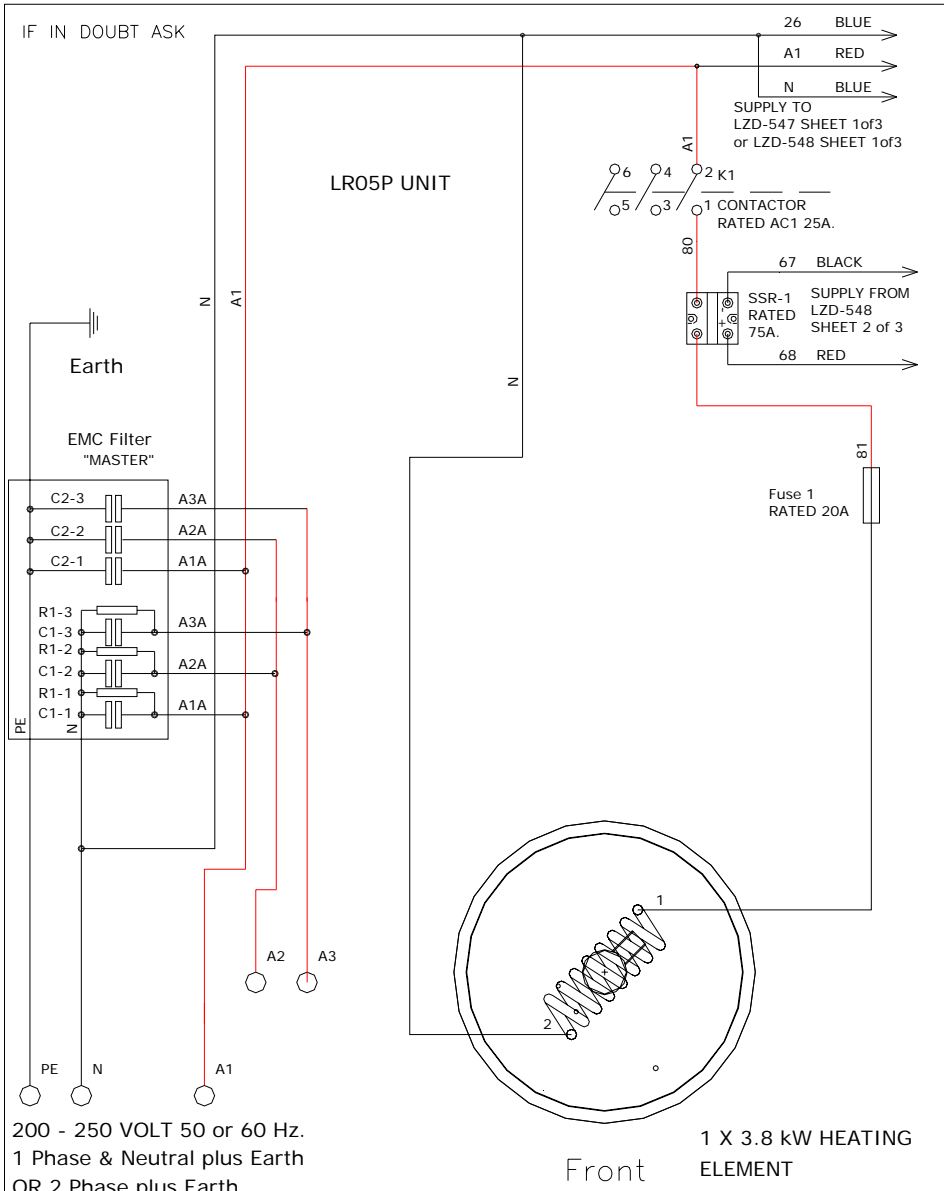

FOR ELECTRICAL LOADS AND POWER SUPPLY DETAILS  
PLEASE REFER TO THE VAPANET LR & LRP INSTALLATION  
OPERATION, MANUAL EDITION 2 OR LATER.

Rev.No.	Revision note	Date	Signature	Checked

Vapac Humidity Control Ltd.  
Fircroft Way, Edenbridge,  
KENT, TN8 6EZ. ENGLAND.  
PHONE +44(0)1732 863447

DR'N : RJW  
CHK'D : X  
PART No./REF. : x

TITLE: VAPAC 5 KG/HR CYLINDER  
POWER CONNECTIONS FOR CYLINDER 1  
LR05P AND LR05 HEATER ELEMENTS  
200 - 250 VOLT 1Ph +N OR 2 Ph.

DRAWING No.: A4-LZD-549

DATE : FEB 02  
ITEM REF : LRP  
SCALE : N.T.S.  
SHEET No. 1 OF 1  
ISSUE : 1



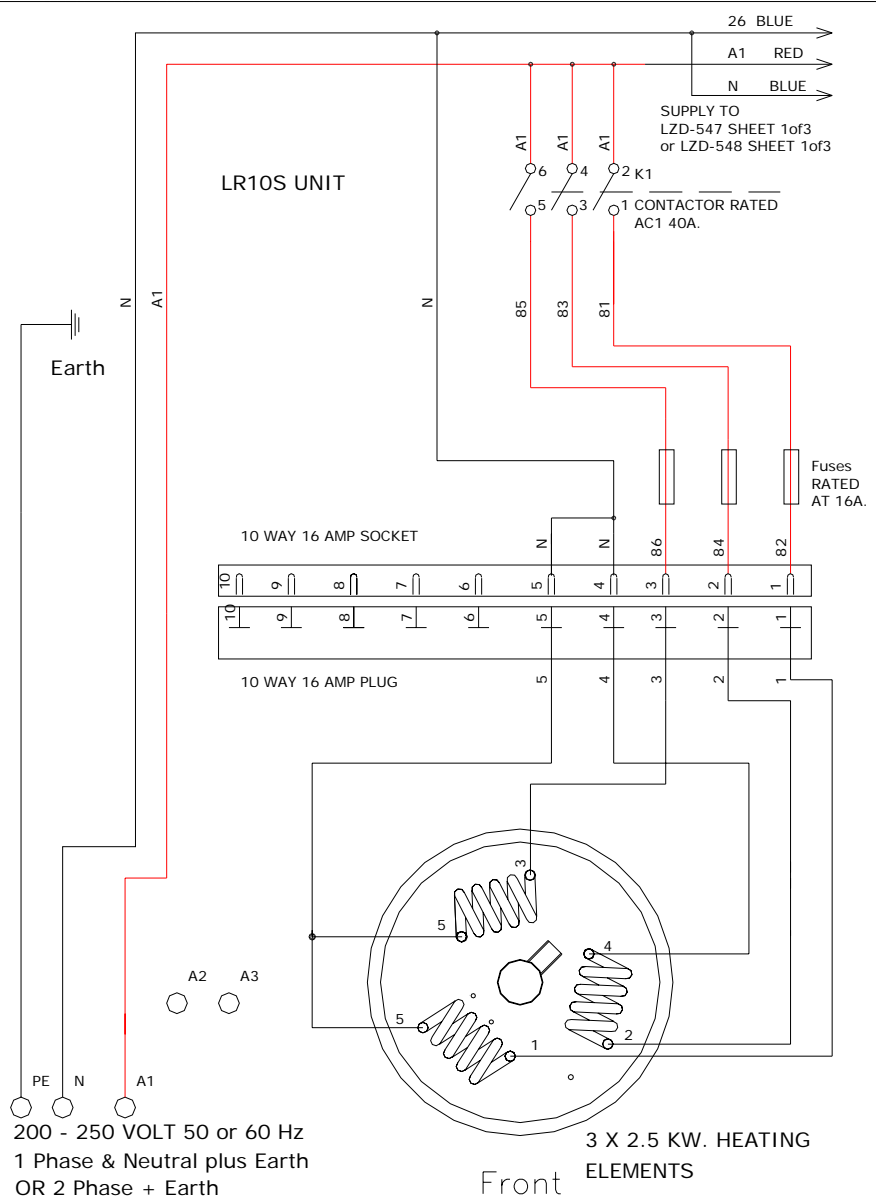
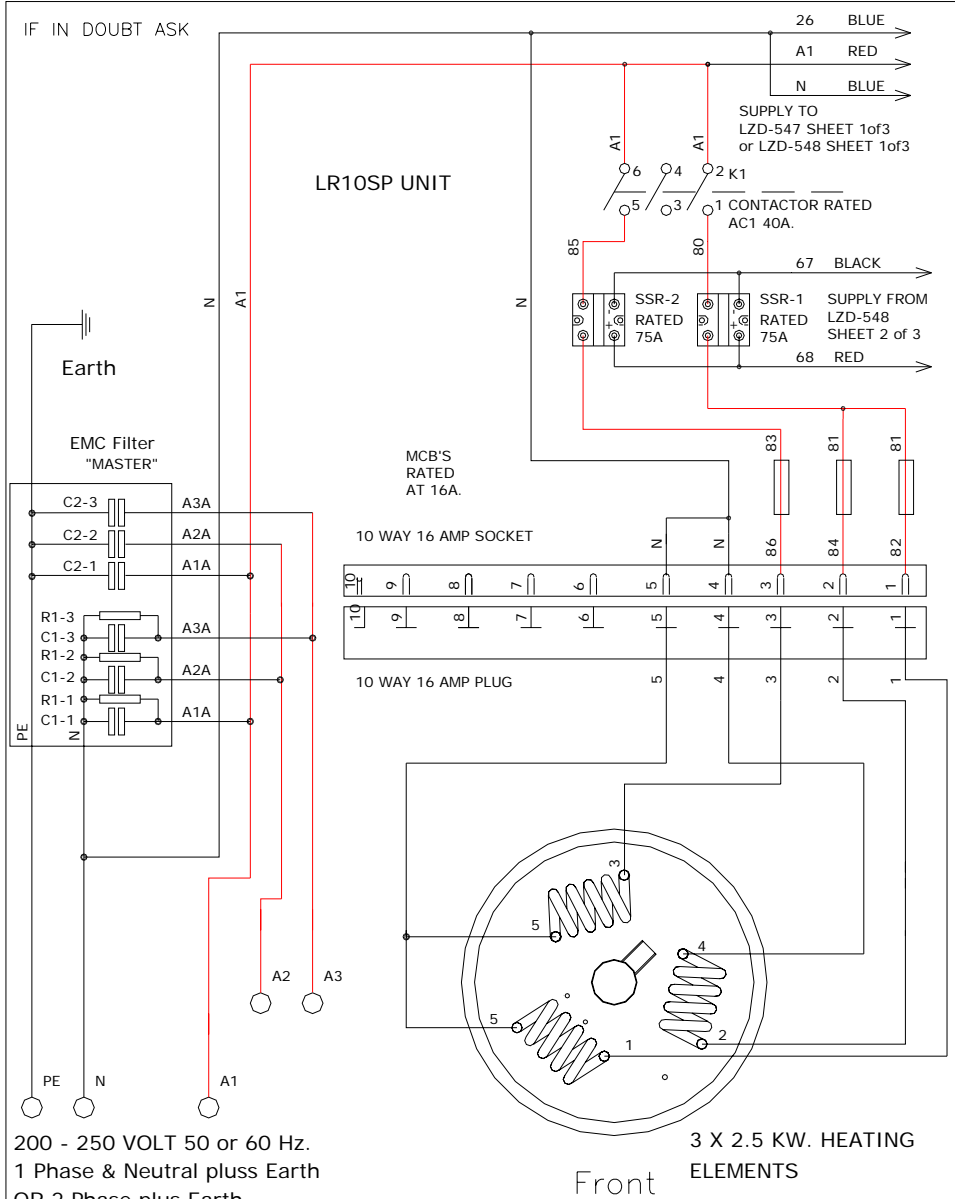

FOR ELECTRICAL LOADS AND POWER SUPPLY DETAILS  
PLEASE REFER TO THE VAPANET RH & RHP INSTALLATION  
OPERATION, MANUAL EDITION 2 OR LATER.

Rev.No.	Revision note	Date	Signature	Checked

Vapac Humidity Control Ltd.  
Fircroft Way, Edenbridge,  
Kent, TN8 6EZ. ENGLAND.  
PHONE +44(0)1732 863447

DR'N : RJW  
CHK'D : X  
PART No./REF.  
x

TITLE: VAPAC 10 KG/HR CYLINDER  
POWER CONNECTIONS FOR CYLINDER 1  
LR10SP AND LR10S HEATER ELEMENTS IN  
PARALLEL FOR 200-250V 1Ph+N or 2Ph.  
DRAWING No.: A4-LZD-550

DATE : FEB 02  
ITEM REF : LRP  
SCALE : N.T.S.  
SHEET No. 1 OF 1  
ISSUE : 1

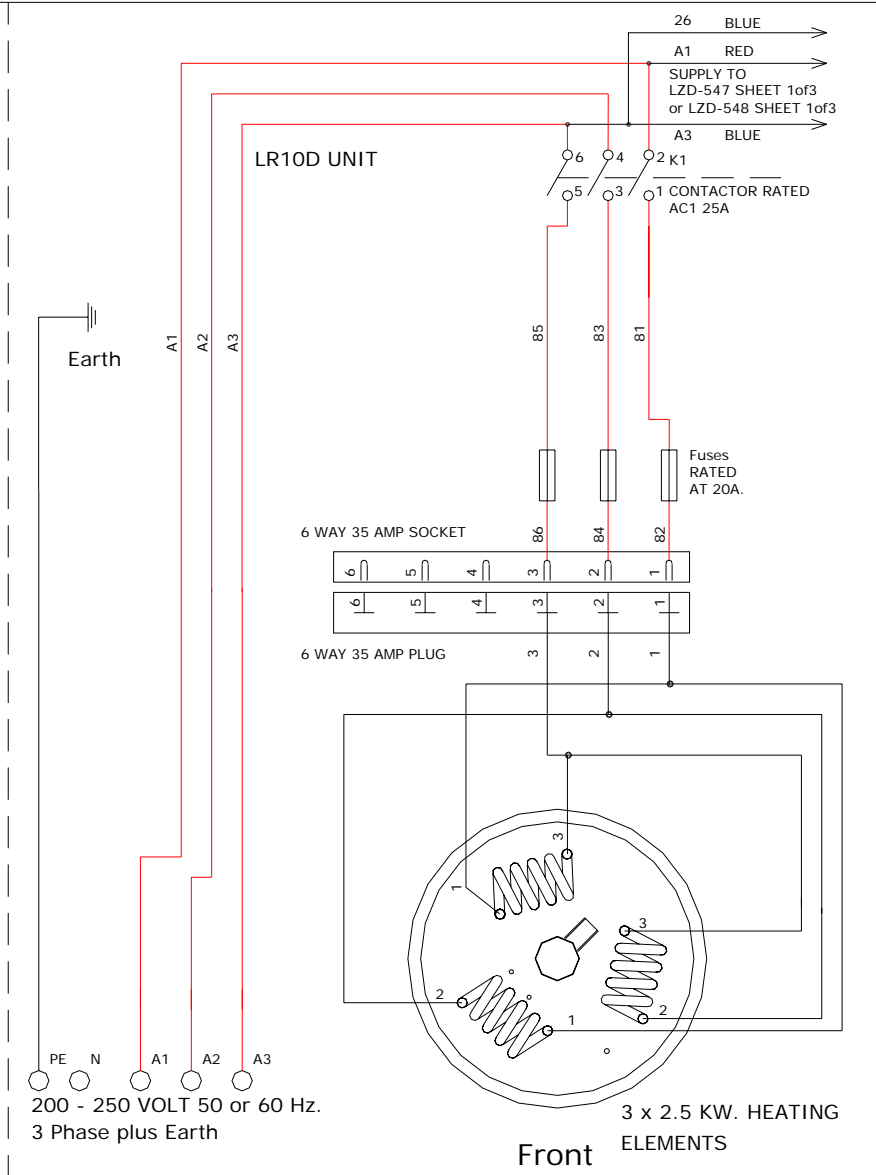
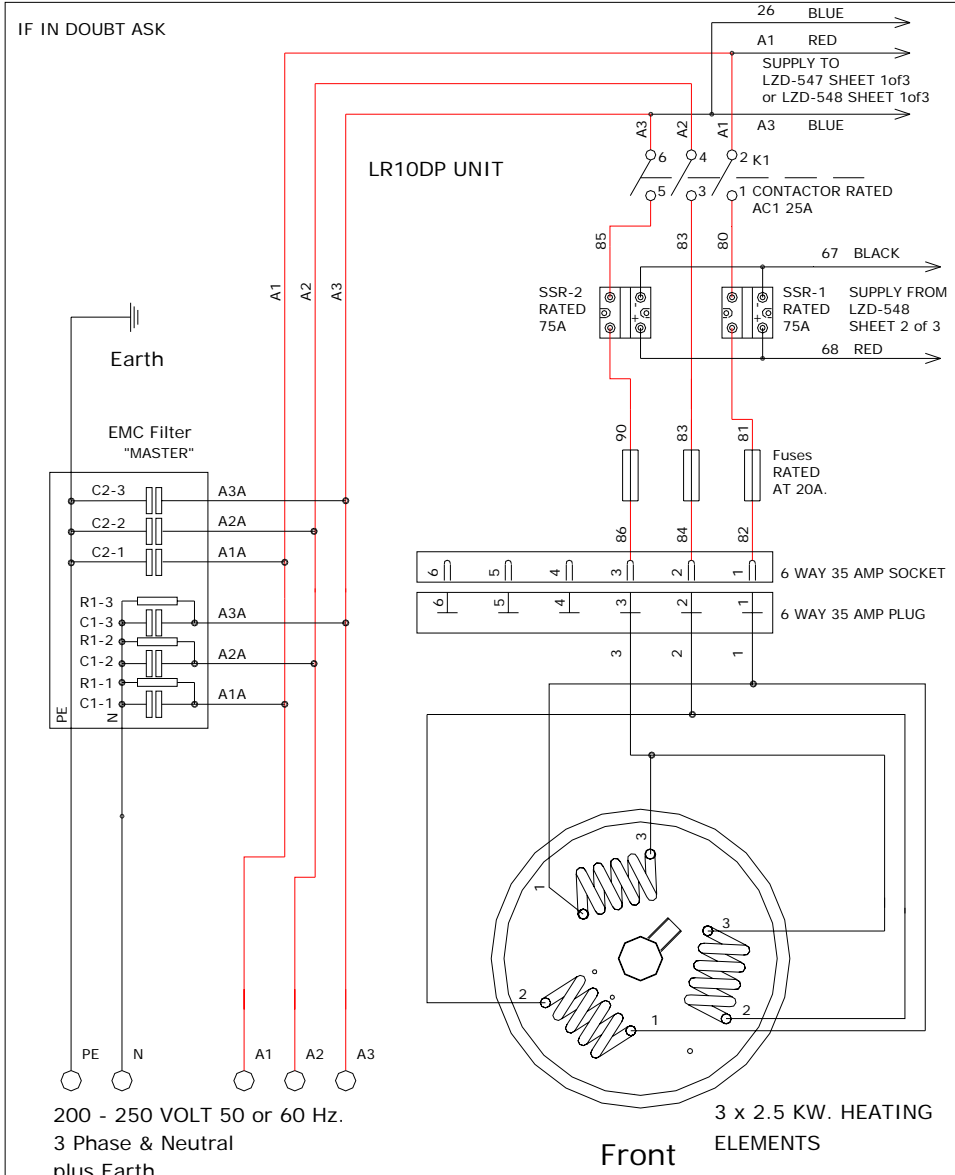

FOR ELECTRICAL LOADS AND POWER SUPPLY DETAILS  
PLEASE REFER TO THE VAPANET LR & LHP INSTALLATION  
OPERATION, MANUAL EDITION 2 OR LATER.

DR'N : RJW
CHK'D : X
PART No./REF. x

Vapac Humidity Control Ltd.  
Fircroft Way, Edenbridge,  
KENT, TN8 6EZ. ENGLAND.  
PHONE +44(0)1732 863447

TITLE: VAPAC 10 KG/HR CYLINDER  
POWER CONNECTION FOR CYLINDER 1  
LR10D AND LR10DP HEATER ELEMENTS  
IN DELTA FOR 200 - 250 V 3 PHASE

DRAWING No.: A3-LZD-552

DATE : FEB 02
ITEM REF : LRP
SCALE : N.T.S.
SHEET No. 1 OF 1
ISSUE : 1

Rev.No.	Revision note	Date	Signature	Checked



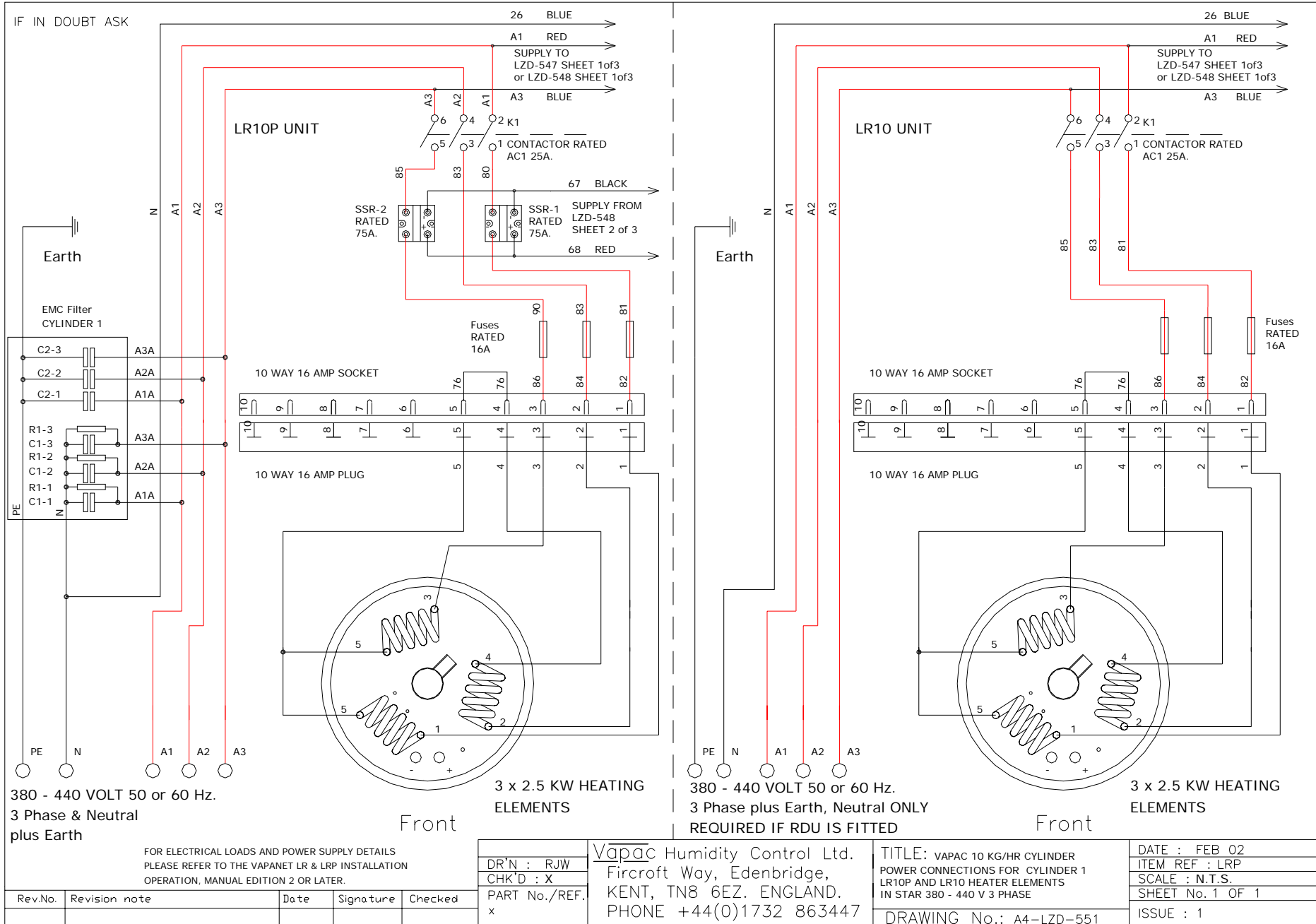

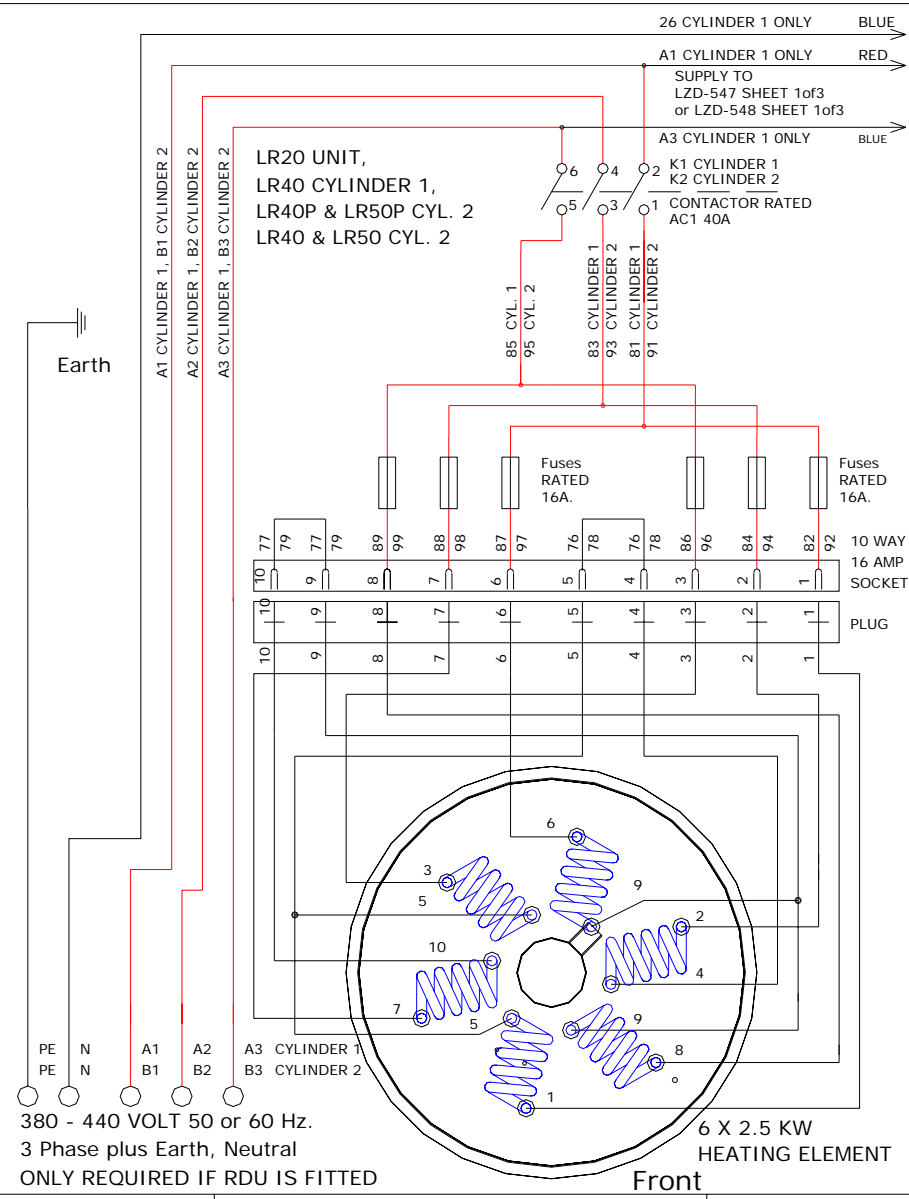
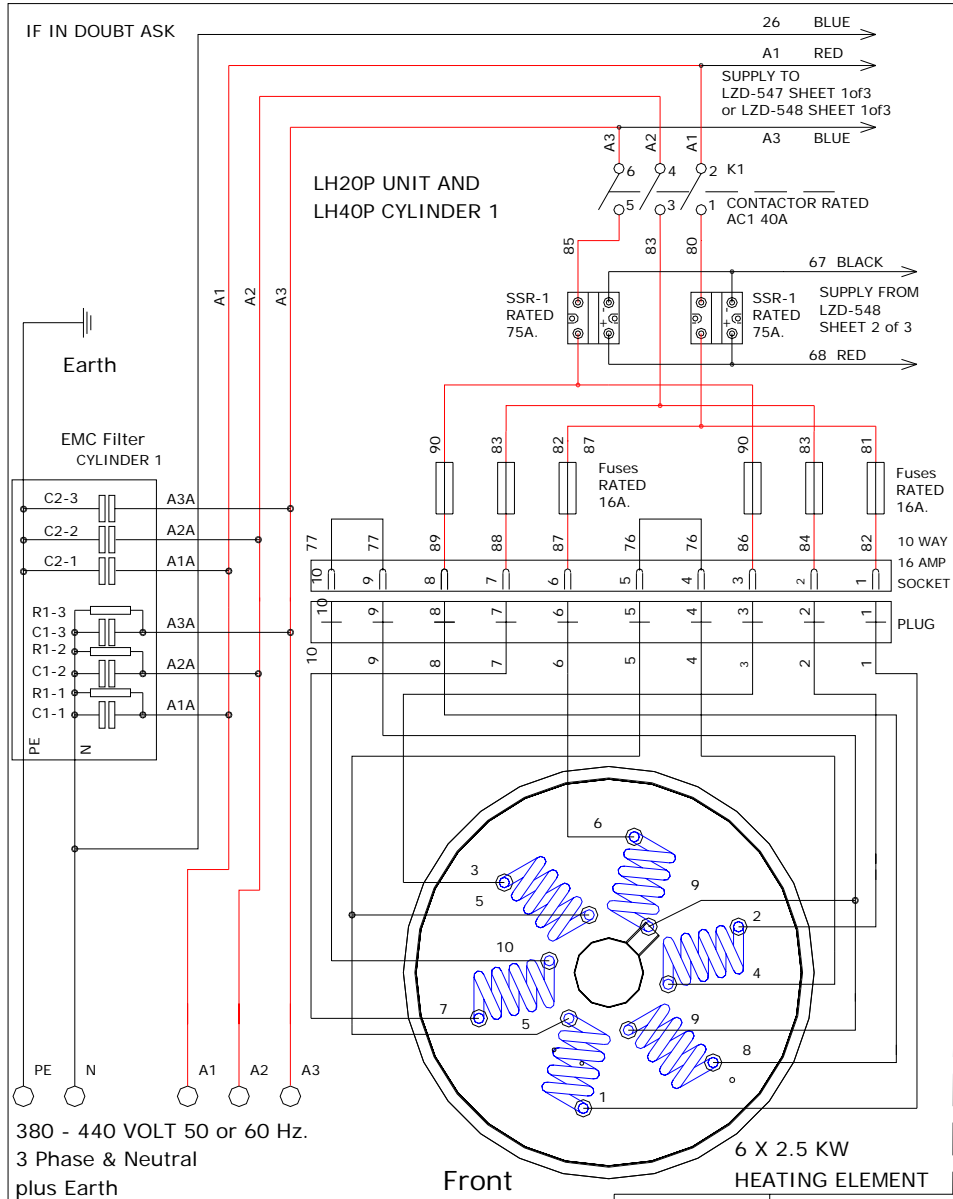

FOR ELECTRICAL LOADS AND POWER SUPPLY DETAILS  
PLEASE REFER TO THE VAPANET LR & LRP INSTALLATION  
OPERATION, MANUAL EDITION 2 OR LATER.

DR'N :	RJW
CHK'D :	X
PART No./REF.	x

Vapac  
Fircroft Way, Edenbridge,  
KENT, TN8 6EZ. ENGLAND.  
PHONE +44(0)1732 863447

TITLE: VAPAC 20 KG/HR CYLINDER POWER CONNECTION  
FOR CYLINDER 1 ON LR20P, LR40P, LR20, & LR40.  
FOR CYLINDER 2 ON LR40, LR50, LR40P, & LR50P  
HEATER ELEMENTS IN STAR FOR 380 - 440 V 3 PHASE

DATE :	FEB 02
ITEM REF :	LRP
SCALE :	N.T.S.
SHEET No. :	1 OF 1
ISSUE :	1

Rev.No.	Revision note	Date	Drn.	Ckd.

DRAWING No.: A3-LZD-553

IF IN DOUBT ASK

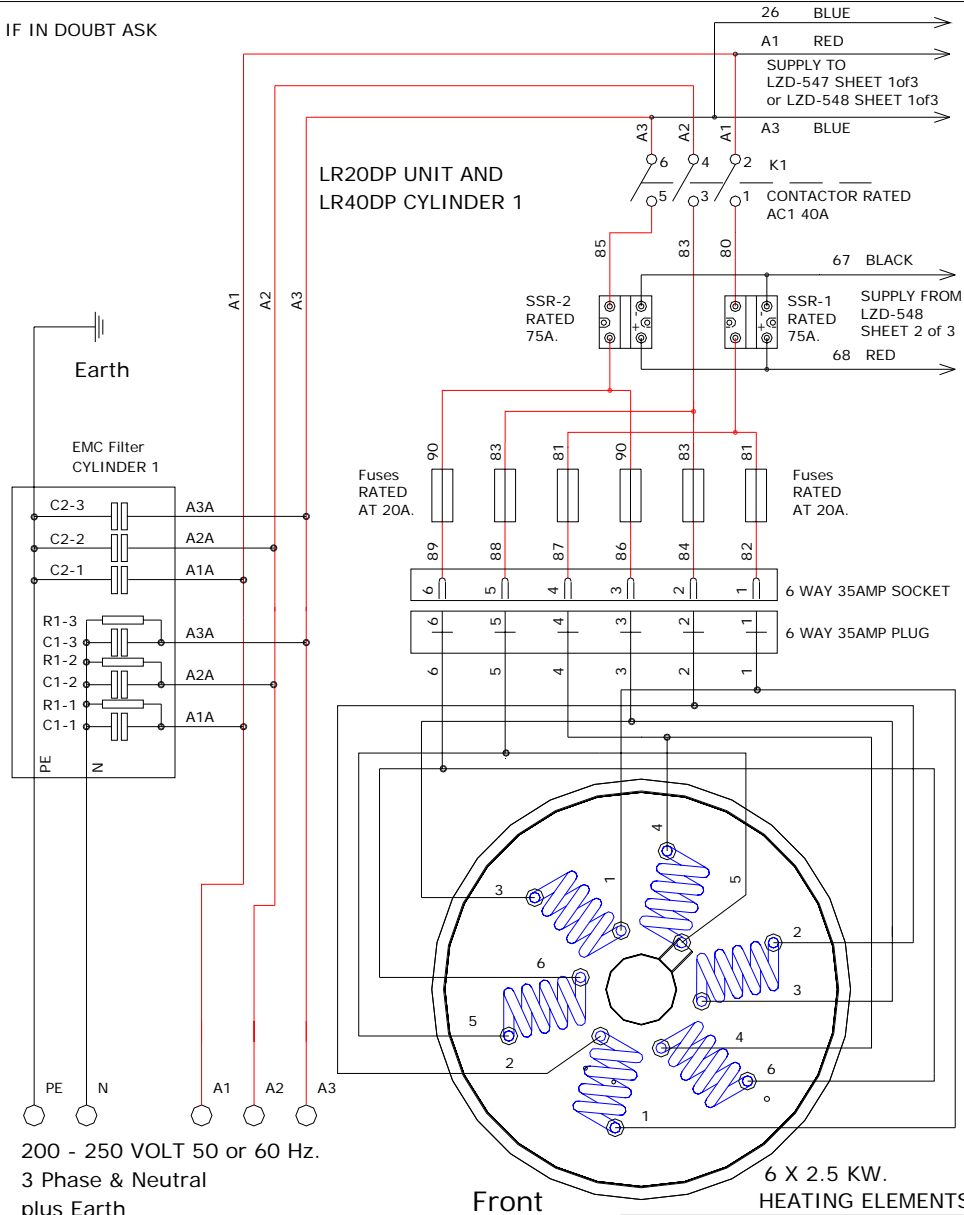

200 - 250 VOLT 50 or 60 Hz.  
3 Phase & Neutral plus Earth

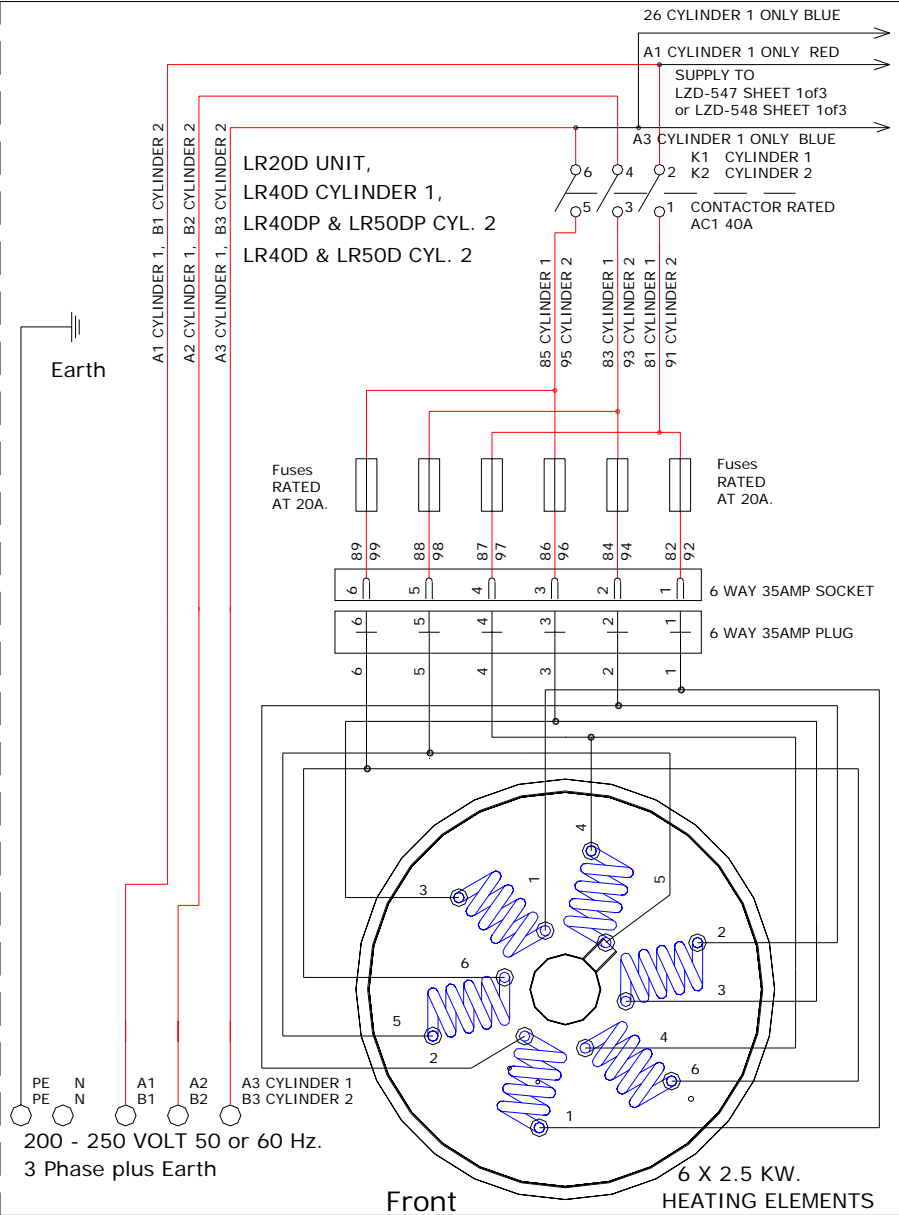

200 - 250 VOLT 50 or 60 Hz.  
3 Phase plus Earth

FOR ELECTRICAL LOADS AND POWER SUPPLY DETAILS PLEASE REFER TO THE VAPANET LR & LRP INSTALLATION OPERATION, MANUAL EDITION 2 OR LATER.

Vapac Humidity Control Ltd.  
Fircroft Way, Edenbridge,  
KENT, TN8 6EZ. ENGLAND.  
PHONE +44(0)1732 863447

DR'N :	RJW
CHK'D :	X
PART No./REF.	x

TITLE: VAPAC 20 KG/HR CYLINDER POWER CONNECTION FOR CYLINDER 1 ON LR20DP, LR40DP, LR20D, & LR40D. FOR CYLINDER 2 ON LR40D, LR50D, LR40DP, & LR50DP HEATER ELEMENTS IN DELTA FOR 200 - 250 V 3 PHASE

DATE :	FEB 02
ITEM REF :	LRP
SCALE :	N.T.S.
SHEET No.	1 OF 1
ISSUE :	1

DRAWING No.: A3-LZD-554

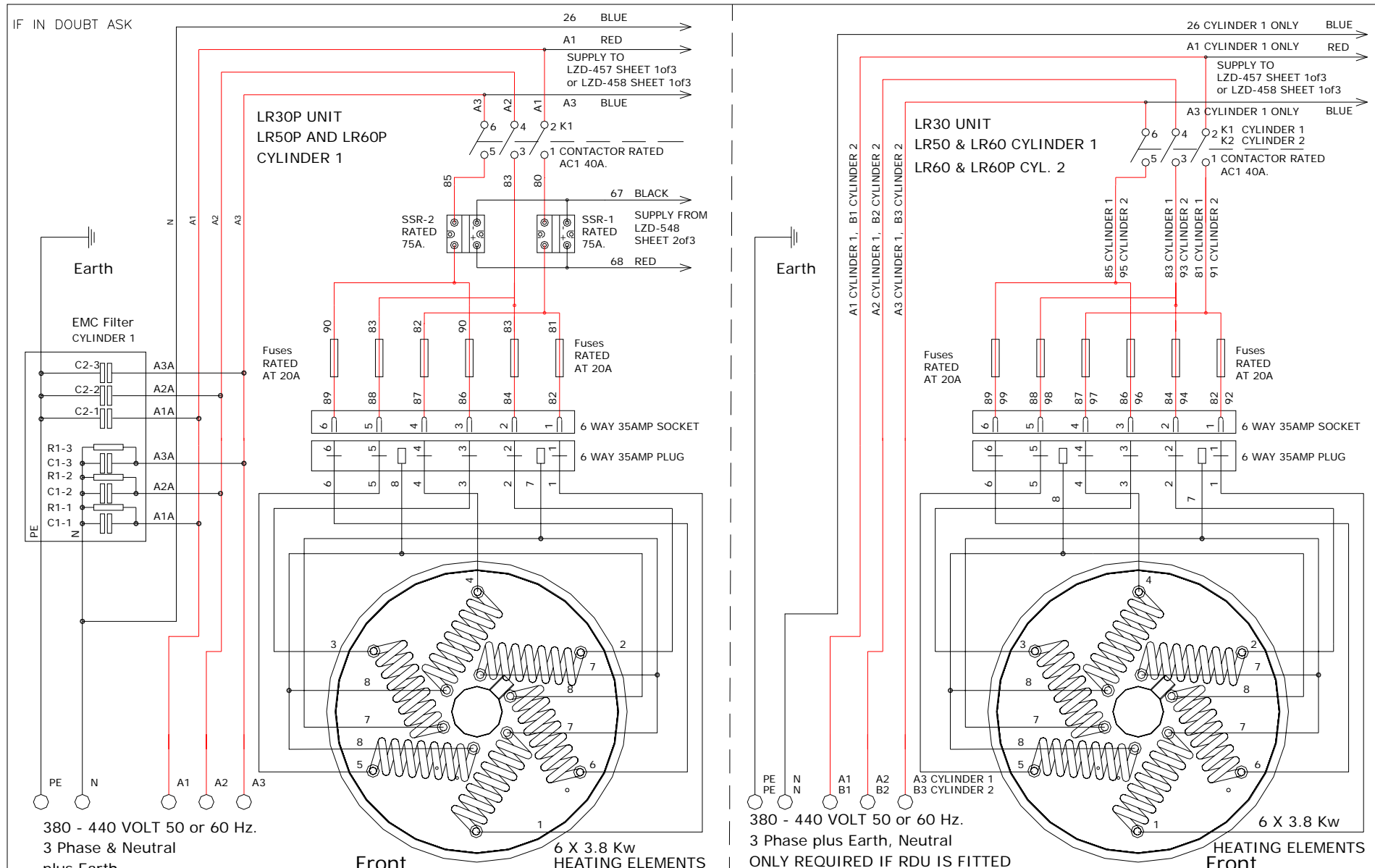

IF IN DOUBT ASK

380 - 440 VOLT 50 or 60 Hz.  
3 Phase & Neutral  
plus Earth

FOR ELECTRICAL LOADS AND POWER SUPPLY DETAILS  
PLEASE REFER TO THE MICROVAP RH & RHP INSTALLATION  
OPERATION, MANUAL EDITION 2 OR LATER.

Rev.No.	Revision note	Date	Drn	Ckd.

DR'N : RJW  
CHK'D : X  
PART No./REF.  
x

Vapac Humidity Control Ltd.  
Fircroft Way, Edenbridge,  
KENT, TN8 6EZ. ENGLAND.  
PHONE +44(0)1732 863447

TITLE: VAPAC 30 KG/HR CYLINDER POWER CONNECTION  
FOR CYLINDER 1 LR30P, LR50P, LR60P, LR30, LR50, &  
LR60. FOR CYLINDER 2 LRP 60 AND LR60 HEATER  
ELEMENTS IN STAR 380 - 440 V 3 PHASE

DRAWING No.: A3-LZD-555

DATE : FEB 02  
ITEM REF : LRP  
SCALE : N.T.S.  
SHEET No. 1 OF 1  
ISSUE : 1

IF IN DOUBT ASK

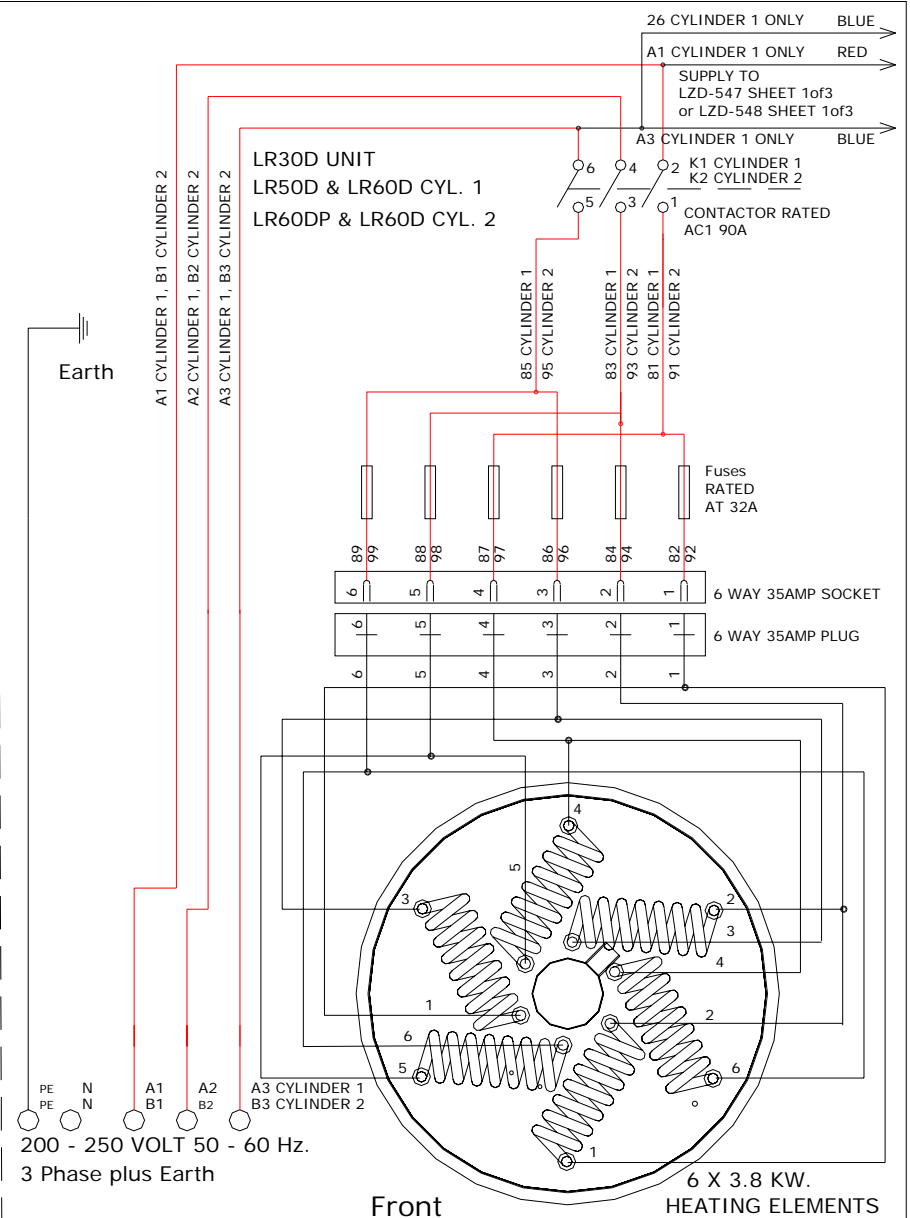
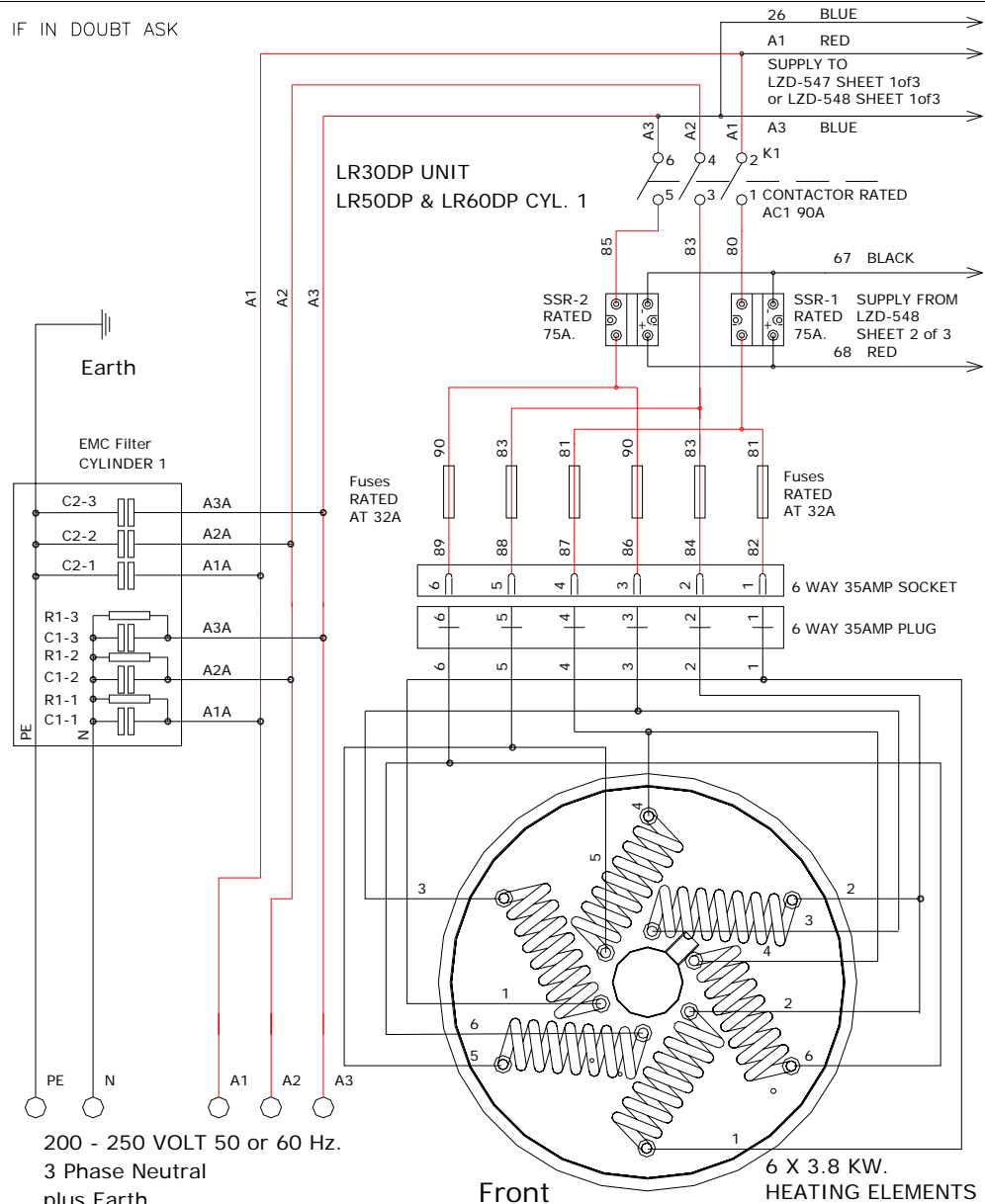

FOR ELECTRICAL LOADS AND POWER SUPPLY DETAILS  
PLEASE REFER TO THE MICROVAP RH & RHP INSTALLATION  
OPERATION, MANUAL EDITION 2 OR LATER.

DR'N : RJW
CHK'D : X
PART No./REF. x

Vapac Humidity Control Ltd.  
Fircroft Way, Edenbridge,  
KENT, TN8 6EZ. ENGLAND.  
PHONE +44(0)1732 863447

TITLE: VAPAC 30 KG/HR CYLINDER POWER CONNECTION  
FOR CYLINDER 1 LR30DP, LR50DP, LR60DP, LR30D, LR50D,  
AND LR60D. FOR CYLINDER 2 LR60DP AND LR60D  
HEATER ELEMENTS IN DELTA 200 - 250 V 3 PHASE

DATE : FEB 02
ITEM REF : LRP
SCALE : N.T.S.
SHEET No. 1 OF 1
ISSUE : 1

DRAWING No.: A3-LZD-556

Rev.No.	Revision note	Date	Drn.	Ckd.

## Appendix 1.

### A Guide to Positioning Steam Pipes:

Vapac Humidity Control Ltd. Issue this as a guide only, and accept no responsibility for the positioning of any pipes in a system. This remains the responsibility of the Project Design Engineer.

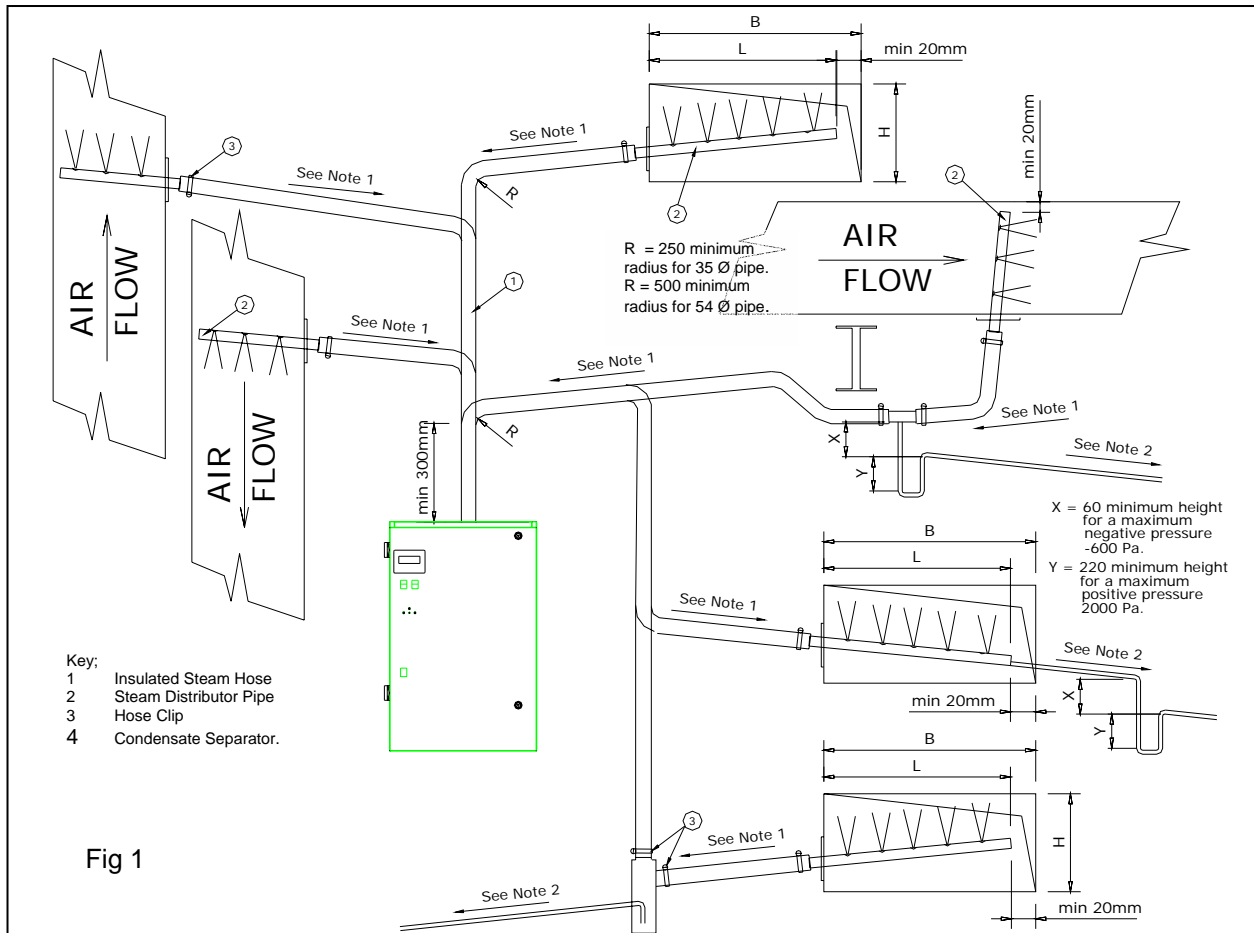

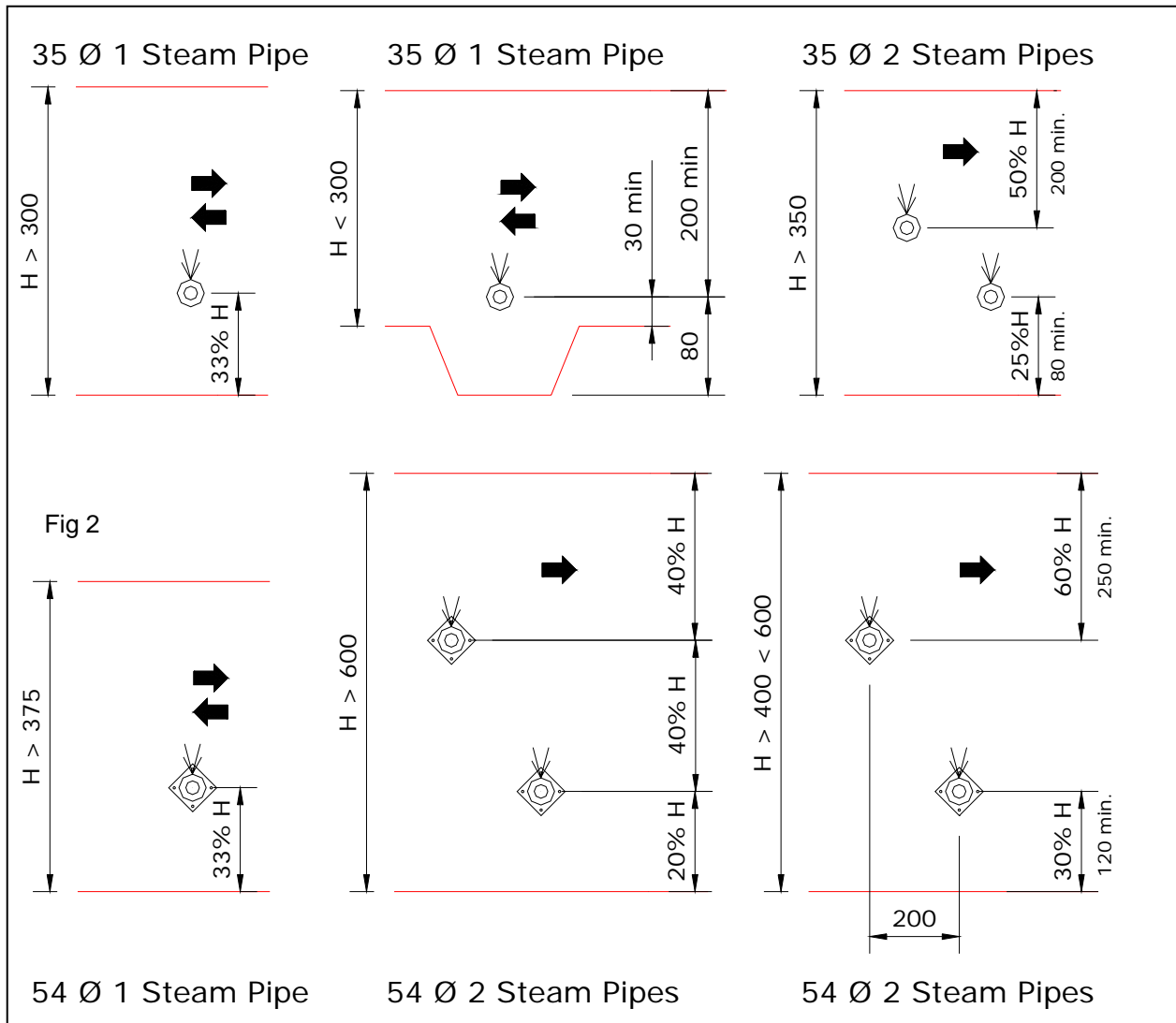

Fig 2

54 Ø 1 Steam Pipe

54 Ø 2 Steam Pipes

54 Ø 2 Steam Pipes

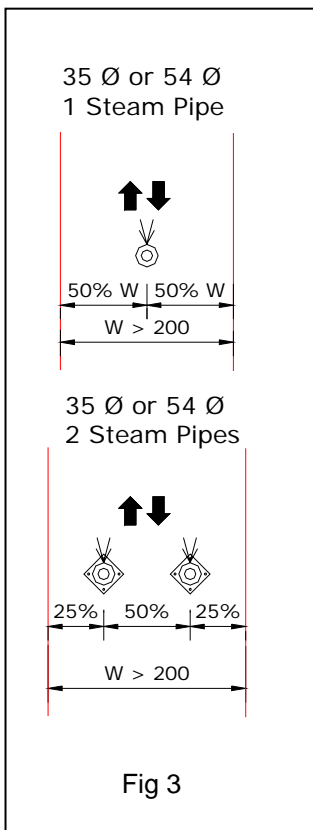

Fig 3

Figure 1 shows the versatility of the steam pipe / steam hose steam delivery system. It also indicates where and how condensate traps / condensate separators should be used. If the steam pipe slopes such that the steam connection is lower than the far end of the pipe, this indicates that a reverse slope steam pipe is required. This is fitted with a drain point to allow condensate to be taken away to a convenient drain.

Figure 2 shows recommendations on how to space one or more steam pipes in a horizontal duct.

Figure 3 shows recommendations on how steam pipes should be spaced in a vertical duct

Figure 4 shows mounting details for 35 and 54 Ø steam pipes

NB. The duct should be clear of obstructions, transformations and bends until the steam has been absorbed into the airflow. A guide to calculating this distance is available from Vapac – Part Number 0411047.

October 02

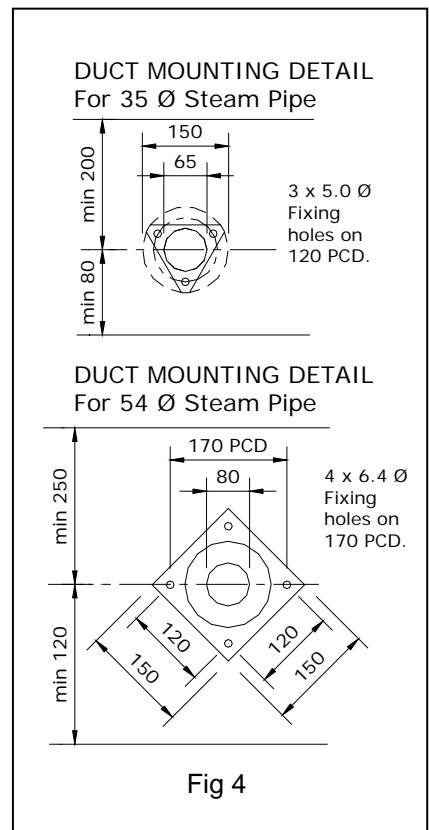
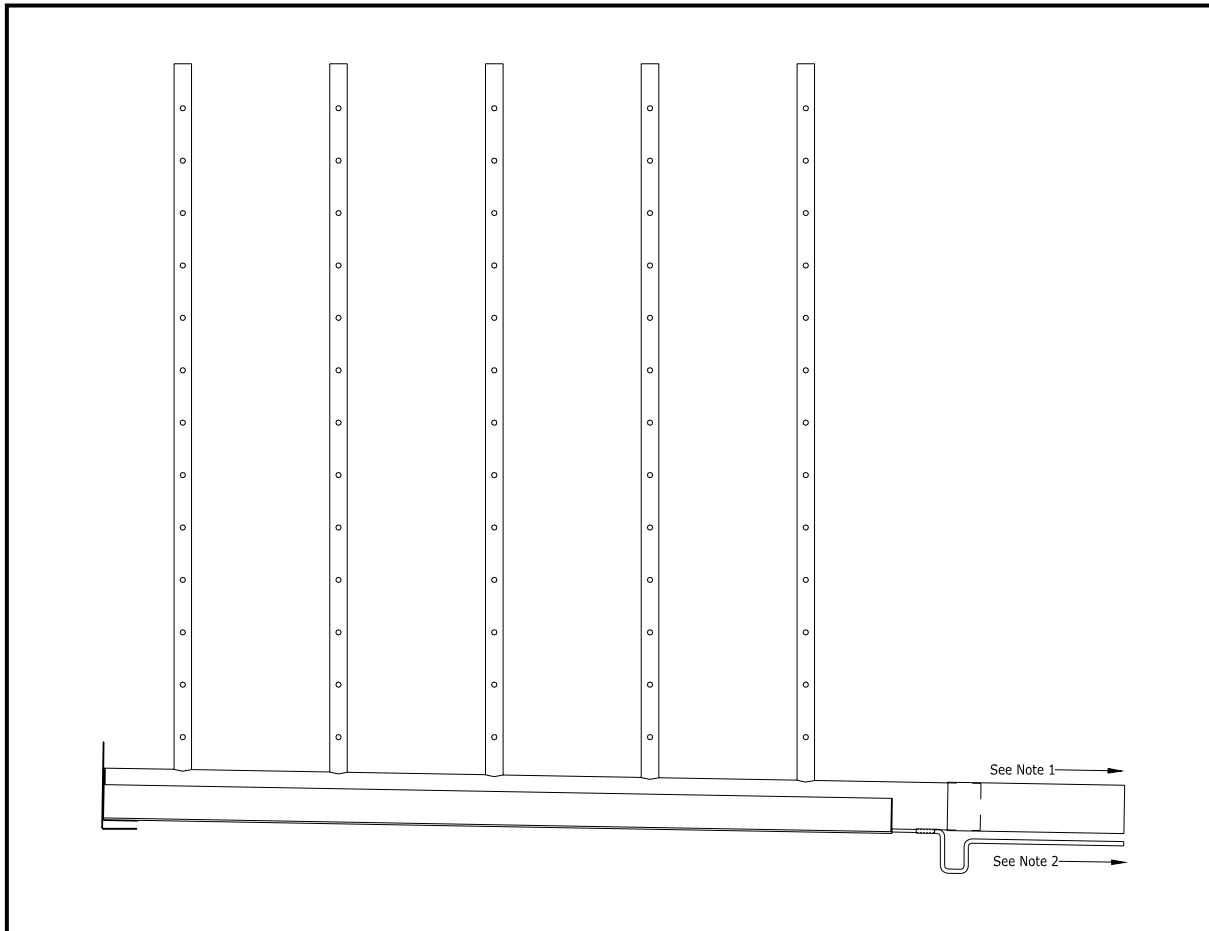

Fig 4

## Appendix 2

### A Guide to Positioning Multipipes:

Vapac Humidity Control Ltd. Issue this as a guide only, and accept no responsibility for the positioning of any pipes in a system. This remains the responsibility of the Project Design Engineer. Notes:



#### Notes:

- 1 Steam pipe to have a minimum slope from the horizontal of 7° or 12% to allow the condensate to drain back to the cylinder or trap. **NO HORIZONTAL RUNS. NO 90° ELBOWS.**
- 2 Water condensate tube to slope at 10° or 18% from the horizontal for condensate to drain back to drain point. A suitably sized trap will be required to prevent steam from escaping via the condensate drain connection.
- 3 Care should be taken to support steam hose sufficiently such that no kinks are formed which would flood with condensate causing the bore of the tube to become constricted, leading to excessive pressure in the steam lines.
- 4 The duct should be clear of obstructions, transformations and bends until the steam has been absorbed into the airflow. Vapac Humidity Control Ltd. Suggest a figure of 1.5 times the estimated absorption distance stated on the "Multipipe" design sheet. Which is supplied with the quotation.
- 5 Should it be necessary to slope the steam hose away from the Vapac Boiler, it will be necessary to fit a condensate separator to remove the condensate at the lowest point. This will need to be taken to a suitable drain.

October, 02

Made in England by:  
Vapac Humidity Control Ltd.

Nov. 2005.

Vapac Humidity Control Ltd. reserve the right to change the design or specification of the equipment described in this manual without prior notice.