

MODUCEL

FLEXAIRE™
AIR HANDLING UNITS



LKP

LKP
RANGE

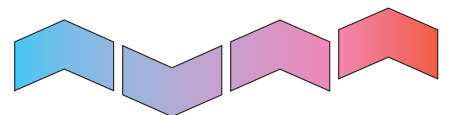

AHU technology at its best

Moducel have over 40 years' experience in the design and manufacture of air handling plant for commercial and industrial applications. They supply hospitals, supermarket chains, leisure stadiums, pharmaceutical buildings and office complexes with uniquely designed solutions to suit each project.

Although Moducel AHU's are designed around a tried and tested standard structure, they have always had the ability to customise the product range to exactly fit project requirements.

A benefit to consultants and contractors, is that when contact is made with the Moducel team in Stoke to assist them with a particular problem, they are assured of receiving the very best expertise and advice in air handling technology.

Moducel have also been supplying for many years a range of fan coil units, having a choice of both waterside and airside control models. These fan coil units offer the specifier and installer unique design features, that provide additional benefits for many diverse applications.



The Eden Project.



Ebor Stand — York Racecourse.



The LKP units are shown in the background, with the LKF compact design at the front.

LKP RANGE

The LKP range of air handling units has been developed using the knowledge gained through the company's many years of proven experience, engineering expertise and understanding of the market requirements. The basis of the LKP design is a robust profile frame, combined with double skinned infill panels. The method of assembly adopted ensures a smooth interior surface, thereby minimizing frictional losses and providing a positive air seal where infill panels are fitted to the frames. The panels are formed from two layers of sheet steel separated by a choice of high quality infill material with excellent thermal and acoustic properties. The modular concept enables the LKP to satisfy the most exacting project criteria. Optimization of unit space produces a lower initial cost product. With the use of high efficiency components and easy access for maintenance, total life costs are minimized.

- Modular Casing Construction giving individual adaptation to project requirements.
- High Standard Specification giving long life expectancy and low 'life cost'.
- Flexible Modular Design giving full optimisation.
- In House Computerised Selection giving quick response to enquiries.
- Several frame options matching design to specification.

Features:

- Boxed pentapost frames.
- High strength double skin panels.
- Full length base channel or feet.
- Galvanised or coated finish.
- Indoor or weatherproof designs.
- Burner / heat recovery options.
- 'Flat pack' or 'Kit form' configuration.
- Warranty options for full life.



LKP Air Volumes (m³/s)

Model	LKP-1	LKP-2	LKP-3	LKP-4	LKP-5	LKP-6	LKP-7	LKP-8	LKP-9	LKP-10	LKP-11	LKP-12	LKP-13	LKP-14
2.5 m/s	0.43	0.875	1.315	1.9725	1.75	2.625	3.505	3.285	4.38	5.475	3.945	5.25	6.575	7.885
3.5 m/s	0.602	1.225	1.841	2.7615	2.45	3.675	4.907	4.599	6.132	7.665	5.523	7.35	9.205	10
4 m/s*	0.688	1.4	2.104	3.156	2.8	4.2	5.608	5.256	7.008	8.76	6.312	8.4	10	10

NOTES: Air Volumes are based on filter velocities. *Extract only.

LKP Nominal Dimensions

Model	LKP-1	LKP-2	LKP-3	LKP-4	LKP-5	LKP-6	LKP-7
30 mm Frame	672w x 437h	672w x 742h	972w x 742h	972w x 1047h	1272w x 742h	1272w x 1047h	1272w x 1352h
40 mm Frame	673w x 438h	673w x 743h	973w x 743h	973w x 1078h	1273w x 743h	1273w x 1048h	1273w x 1353h
50 mm Frame	715w x 480h	715w x 785h	1015w x 785h	1015w x 1090h	1315w x 785h	1315w x 1090h	1315w x 1395h
70 mm Frame	—	—	—	—	—	—	—

Model	LKP-8	LKP-9	LKP-10	LKP-11	LKP-12	LKP-13	LKP-14
30 mm Frame	—	—	—	—	—	—	—
40 mm Frame	1573w x 1048h	1573w x 1353h	1573w x 1658h	1873w x 1048h	1873w x 1353h	1873w x 1658h	1873w x 1963h
50 mm Frame	1615w x 1090h	1615w x 1395h	1615w x 1700h	1915w x 1090h	1915w x 1395h	1915w x 1700h	1915w x 2005h
70 mm Frame	1623w x 1098h	1623w x 1403h	1623w x 1708h	1923w x 1098h	1923w x 1403h	1923w x 1708h	1923w x 2013h

LKP SECTION DATA UNITS 1-7

Approximate Section Weights (Kg)

Model	LKP-1	LKP-2	LKP-3	LKP-4	LKP-5	LKP-6	LKP-7
Fan	70	92	136	166	166	238	360
Diffuser	20	25	31	61	61	70	78
Plenum 300 mm	19	22	25	34	34	40	44
Plenum 600 mm	30	35	43	60	60	68	76
Plenum 900 mm	40	48	61	85	85	97	108
Plenum 1200 mm	50	62	80	110	110	125	140
Mixing Box 600 mm	42	49	61	87	87	106	124
Mixing Box 900 mm	—	64	82	117	117	141	164
Mixing Box 1200 mm	—	—	—	—	—	175	204
Damper	6	9	12	18	18	25	32
Pad Filter	42	49	62	73	73	87	99
Pad/Bag Filter	62	69	85	100	100	120	135
Bag Filter	42	49	62	73	73	87	99
Steam Humidifier	60	75	90	120	120	145	170
Coil 1 Row	20	31	34	51	51	64	75
Coil 2 Row	23	35	38	60	60	74	93
Coil 4 Row	35	54	70	100	100	122	147
Coil 5 Row	37	57	75	108	108	135	160
Coil 6 Row	39	61	80	115	115	146	173
Coil 7 Row	41	64	85	125	125	156	187
Coil 8 Row	44	68	90	136	136	167	209
Electric Coil	24	31	34	51	51	64	75
Silencer 900 mm	60	87	104	128	128	155	183
Recuperator	On Application						
Heat Wheel	On Application						
Indirect Heater	—	—	78	85	85	92	140
Weather Proof (per metre)	17	17	20	20	20	22	22

Approximate Section Lengths (mm)

LKP Model	LKP-1	LKP-2	LKP-3	LKP-4	LKP-5	LKP-6	LKP-7
Fan	700	1000	1000	1300	1300	1300	1600
Diffuser	400	700	700	700	700	700	700
Mixing Box	300	300	300	300	600	600	600
Damper	165	165	165	165	165	165	165
Pad Filter	200	200	200	200	200	200	200
Pad/Bag Filter	600	600	600	600	600	600	600
Bag Filter	500	500	500	500	500	500	500
Steam Humidifier	1000	1000	1000	1000	1000	1000	1000
Coil 1 Row	200	200	200	200	300	300	300
Coil 2 Row	200	200	200	200	300	300	300
Coil 4 Row	500	500	500	500	500	500	500
Coil 5 Row	500	500	500	500	500	500	500
Coil 6 Row	600	600	600	600	600	600	600
Coil 7 Row	700	700	700	700	700	700	700
Coil 8 Row	700	700	700	700	700	700	700
Electric Coil	800	800	800	800	800	800	800
Silencer	900	900	900	900	900	900	900
Recuperator	On Application						
Heat Wheel	1300	1300	1300	1300	1300	1300	1300
Indirect Heater	On Application						

LKP SECTION DATA UNITS 8-14

Approximate Section Weights (Kg)

Model	LKP-8	LKP-9	LKP-10	LKP-11	LKP-12	LKP-13	LKP-14
Fan	360	399	558	399	558	616	675
Diffuser	78	87	102	87	102	112	168
Plenum 300 mm	44	50	60	50	60	66	70
Plenum 600 mm	76	85	100	85	100	109	117
Plenum 900 mm	108	120	140	120	140	153	164
Plenum 1200 mm	140	155	180	155	180	196	211
Mixing Box 600 mm	124	147	174	147	174	193	219
Mixing Box 900 mm	164	192	226	192	226	251	283
Mixing Box 1200 mm	204	237	278	237	278	308	347
Damper	32	41	49	41	49	56	68
Pad Filter	99	115	137	115	137	155	168
Pad/Bag Filter	135	156	185	156	185	207	229
Bag Filter	99	115	137	115	137	155	168
Steam Humidifier	170	180	210	180	210	223	234
Coil 1 Row	75	88	121	88	121	141	159
Coil 2 Row	93	110	132	110	132	167	189
Coil 4 Row	147	180	204	180	204	229	275
Coil 5 Row	160	197	223	197	223	262	300
Coil 6 Row	173	224	252	224	252	285	327
Coil 7 Row	187	242	272	242	272	308	354
Coil 8 Row	209	261	291	261	291	330	382
Electric Coil	75	88	121	88	121	141	159
Silencer 900 mm	183	215	264	215	264	295	332
Recuperator	On Application						
Heat Wheel	On Application						
Indirect Heater	140	186	571	186	571	594	617
Weather Proof (per metre)	22	28	28	30	30	30	30

Approximate Section Lengths (mm)

Model	LKP-8	LKP-9	LKP-10	LKP-11	LKP-12	LKP-13	LKP-14
Fan	1600	1600	1600	1300	1600	2000	2000
Diffuser	700	700	700	700	700	700	700
Mixing Box	900	900	900	600	600	900	900
Damper	165	165	165	165	165	165	165
Pad Filter	200	200	200	200	200	200	200
Pad/Bag Filter	600	600	600	600	600	600	600
Bag Filter	500	500	500	500	500	500	500
Steam Humidifier	1000	1000	1000	1000	1000	1000	1000
Coil 1 Row	300	300	300	300	300	300	300
Coil 2 Row	300	300	300	300	300	300	300
Coil 4 Row	500	500	500	500	500	500	500
Coil 5 Row	500	500	500	500	500	500	500
Coil 6 Row	600	600	600	600	600	600	600
Coil 7 Row	700	700	700	700	700	700	700
Coil 8 Row	700	700	700	700	700	700	700
Electric Coil	800	800	800	800	800	800	800
Silencer	900	900	900	900	900	900	900
Recuperator	On Application						
Heat Wheel	1300	1300	1300	1300	1300	1300	1300
Indirect Heater	On Application						

CONFIGURATION

Air handling units are the core of air conditioning systems with the basic task to combine, within a single unit, components such as filters, heat-exchangers, humidifiers and fans, together with other specialized air treatment components as the application dictates. These have to be combined in such a way, not only to minimize on space and

maintenance requirements, but to function efficiently so as to ensure that the optimum performance is achieved. Ecological demands, acoustic characteristics and the specification of materials to be used are important design factors. All this has an effect on the overall configuration of the unit.

Some Examples — Other Configurations Available

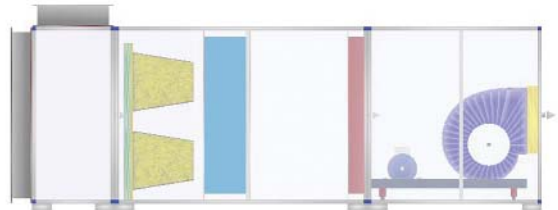
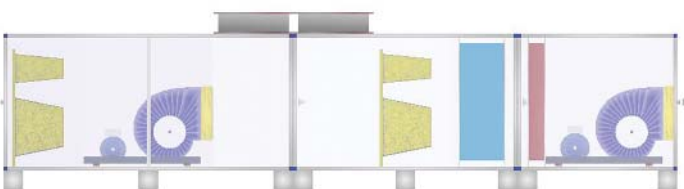
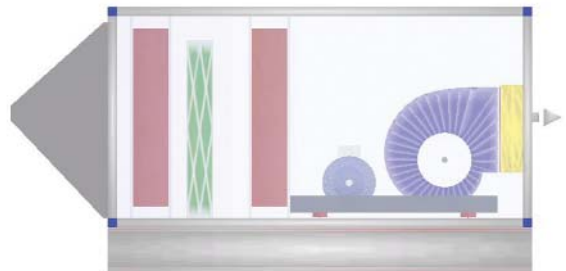
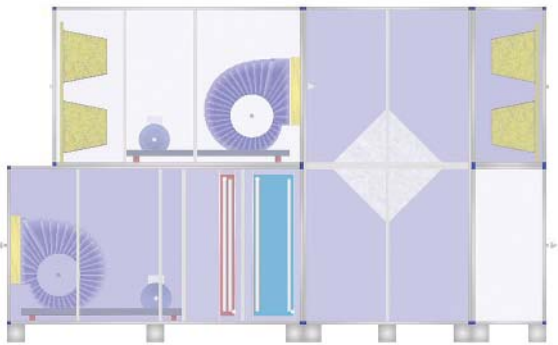
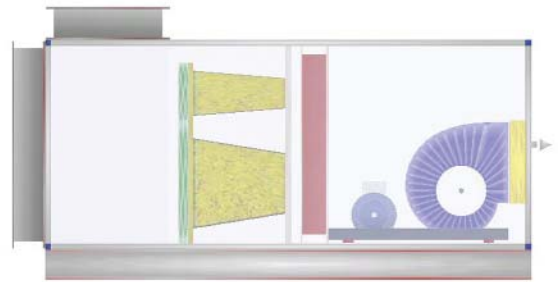
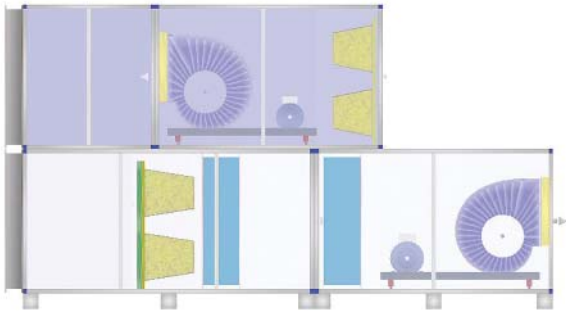

Accessories:

- Isolators.
- Manometers.
- Control Box.

Services:

- Site rebuild for 'Flat pack' and 'Kit form'.
- Project management from supply through to commissioning.
- Maintenance programmes full 24/7 capability.
- Extended warranty packages up to full life.
- Site survey to check suitability of unit selected.

Quality & Standards:

- ISO 9001
- CE
- BSRIA
- FETA / HEVAC

Options Available

Plastisol panels outer and/or inner are available in goose wing grey for applications where resistance to corrosion (weather resistant) is required.

Base lifting points

Lifting shackles are available for base heights 150 mm only.

Coolag insulation in 25 mm thick panels.

Coolag insulation is available in order to enhance thermal properties whilst maintaining a panel thickness of 25 mm. The 'K' value of coolag is 0.023 WmK.

Guards

Both drive guards and door guards are available. Drive guards would be manufactured using 12 x 50 mm weld mesh. Door guards would be manufactured from 1 mm galvanized steel sheet.

Bulkhead lights

Lights and switches are available. Standard 100 W GLS, BC in an IP55 enclosure are flush mounted, creating a good seal.

Portholes

Portholes of 218 mm diameter are available for 25, 45 and 50 mm thickness of panels.

Manometers

Inclined gauge manometers are available. Operating range 0-400 pa.

Minihelic gauges

Minihelic gauges are available offering the latest in design features for a dial type manometer. Operating range 0-400 pa.

Pressure switches

Pressure switches are available with range bands of 0.2 to 3 mbar and 1 to 10 mbar. Both switches have a change over contact and an IP54 enclosure.

Motor Isolators

Fully insulated local motor isolators within an IP65 enclosure are available. All isolators are lockable and conform to IEC/EN 60204, IEC/EN 60947-3 and EN 50262.

Heat Recovery Section

Heat recovery wheels (either constant or variable speed).

Controls

Controls packages are available.

1

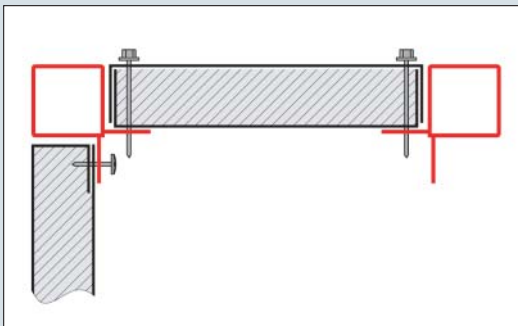

2

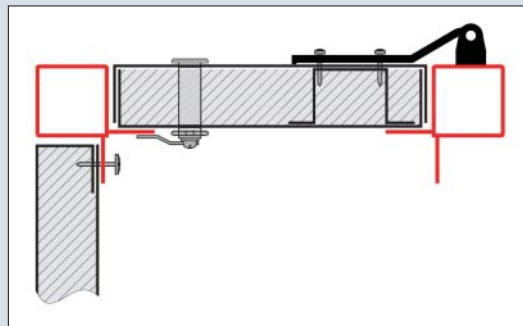

1. Inside and outside fixing options.
2. Door lock and door hinge.

UKP

General Construction

The unit sections comprise chassis frame of extruded aluminium pentapost section with aluminium corner pieces. Inset cover panels of optional 25 mm, 45 mm, or 50 mm nominal thickness are available manufactured from 1 mm double skinned galvanised steel with 45 kg/m³ mineral wool insulation ('K' value 0.034 WmK). Fixed panels are fastened internally using gaskets and plated drill screws. Removable panels are fastened externally using gaskets and plated drill screws. Access doors are fitted with rubber seals and can be either lift off or hinged. Air leakage to meet the HEVAC standard.

Unit Supports

Unit supports will be either feet, formed bases, or for heavy sections, RSC bases. Feet and formed bases will be manufactured from 3 mm thick galvanized steel.

Fan Section

The fan section is constructed from chassis frame and cover panels as previously described, and will incorporate a DIDW forward/backward curved fan driven by means of a TEFC metric motor via a vee belt drive. The vee belt drive will be selected to operate on a continuous (24 hour) basis, particular attention being paid to the loads imposed on the fan bearings. The fan and motor will be mounted on a sub frame, isolated from the unit casing by spring anti-vibration mountings and flexible connection off the fan discharge. Fans will have single row self aligning sealed for life ball bearings. The bearings will be selected with a minimum design life of 40,000 hours giving as average life of 100,000 hours.

Heater Batteries (LPHW)

Heater battery fin blocks will be manufactured from ½" O/D seamless copper tube (0.5 mm wall thickness) on to which 0.15 mm thick aluminium fins are mechanically bonded. The copper tubes will be brazed into copper headers fitted with BSP male screwed connections. The heater battery will be circuited in a contra-flow arrangement, with the connections on one side only. The battery casing will be manufactured from 16 gauge galvanised steel folded to a rigid section enclosing both 'U' return bends and flow/return headers. Batteries will be tested with nitrogen under water to 24 bar.

Frost protection heaters will be 1 row with wide fin spacings (160FPM) as standard.

Cooler Batteries (CW & DX)

The cooler battery will be similar to LPHW heater batteries, except that the casings will be arranged to provide a one piece drain pan under the fin block, return bends and headers. Cooler batteries above 1500 mm face height will be provided with intermediate drip tray and drain tubes. DX coils will be circuited to suit the application and will use refrigeration quality copper tube and headers. All cooling coils will be complete with an integral plastic blade eliminator.

Filter Section

Filter section will be manufactured from chassis frame and cover panels as previously described, and be provided with special purpose holding frames to accept the type of filter being used, suitable for side withdrawal.

Types of filters offered in the standard range are 50 and 100 mm thick G3 and 4 grade disposable panel filters and F5 to 8 grade 380 mm long disposable synthetic bag filters.

Mixing/Inlet Plenums

These sections will be constructed from chassis frame and cover panels as previously described, and fitted with parallel or opposed bladed multi-leaf dampers suitable for manual or motorised operation, dependant on specification. Dampers will be constructed from galvanised steel. Mixing dampers will be provided with individual motor mounting plates or hand quadrants.

Weatherproof Units

The component sections will be factory assembled on to a common formed or RSC base. The top of the complete unit will be covered by a roof section to provide wet weather protection. Fresh air intake and exhaust air outlets will be fitted with hoods, complete with bird-mesh wire screen or with outside weather louvres constructed from HE9 extruded aluminium section having satin finish and fitted with expanded aluminium bird mesh screen. Access doors will be provided where required lifting points are fitted as standard.

Indirect Gas Fired Air Heater Sections (Pressure Jet Fired Type)

The section will incorporate a heavy gauge mild steel plate heat exchanger, having a stainless steel primary combustion chamber and an all welded mild steel secondary heat exchanger, it will be designed for long life and will be completely gas tight. A fully automatic pressure jet burner will be flange mounted to the combustion chamber, providing a high efficiency output combined with quiet and stable flame performance. The burner will be complete with gas valve train incorporating governors, double block safety shut off valves and test points. Burner safety controls only are provided.

A stainless steel flue pipe with weather cowl will be fitted on weatherproofed units.

Indirect Gas Fired air heater sections (Atmospheric Burner Type)

The section will incorporate a stainless steel multiple section 'Venturi' pattern heat exchanger with a multi-gas, die formed, corrosion resistant, aluminised steel burner having flared ports and stainless steel ribbon. The unit will include facilities for simultaneous adjustment of the primary air to all burners from a single point in the control compartment. Burners will be jetted to suit the particular gas specification. The burner assembly will be arranged to slide out of the heat exchanger for easy access. Units will be provided with automatic spark ignition. Power vented flues are standard (flue pipe not provided) or flue-less (weatherproof units only). On/off, 2 stage or modulating burner are available (subject to suitability or gas supply). In all cases the heater will incorporate flame failure and over temperature protection. Power vented units will incorporate flue fan failure protection.

Plate Recuperator Section

The plate recuperator section will be constructed from chassis frame and cover panels as previously described and will incorporate a cross flow plate recuperator selected to suit the supply and extract air volumes and conditions. Recuperator will be constructed from high purity aluminium plates retained within a galvanised sheet steel casing. In applications requiring a recuperator bypass the bypass duct will be incorporated within the recuperator section and will be controlled by means of a special combined face/bypass damper requiring a single actuator (face opens as bypass closes and vice-versa). A drain tray will be provided in the recuperator extract air stream to catch any condensate. The recuperator plates are designed and spaced to offer optimum heat reclaim with negligible risk of core blockage by contaminants in the airstream.

Humidifier Sections

These sections will be constructed from chassis frame and panels as previously described, and will be complete with a drain tray. The section length will be as required for the supplied humidifier. We can supply both electric steam generator humidifiers and live steam models.

Attenuator Sections

These sections will be constructed from chassis frame and panels as previously described and will incorporate splitters which will be either 600, 1200 or 1800 mm long as required. Splitters will be perf faced tissue covered mineral wool, or, for moist air, perf faced melinex bagged mineral wool. Splitters are fitted with bullnose fairings as standard.

QUOTATION REQUEST

Please fill in and tick boxes where appropriate.

CUSTOMER	Name:		Date:	
	Address:		Customer Ref:	
			Quotation No:	
			Revision:	
	Post Code:		E-mail:	
Tel:		Fax:		

DETAILS No. Off Int Ext Air Vol Ext PD

MIX BOX Yes No **Actuators:** Hand Motor

Notes

FILTERS **Pad:** 3 4 **Bag:** 4 5 6 7 8/9

Hepa: 13 **Options:** Man Gauges: Mag Min Pd Sw

Notes

COILS **Frost:** PT Fin Elec **Reheat:** Fin Elec **Cooling:** CW/DX

Construction: Construction: Construction:

Media: Media: Media:

Temperature: Temperature: Temperature:

kW kW kW

On Off On Off On Off

Notes

MISC **Heat Reclaim:** RA Wheels Recups Face/Bypass

Conditions: Efficiency:

Access Sections: Min Lg

Humidity: Self Gen Direct Steam Other Kg/hr Steam Press

Burners: Direct Indirect On/Off Hi/Low Mod

Other: kW

Notes

FAN SECTION **Fan:** BC FC Discharge: UP End Other

Motor: Int Ext EF1 EF2 Run RSB Inverters

Notes

GENERAL **Specification:** CO4 Other

Restrictions: Size Access Weight Run Current Noise Other

Notes

Completed By:

Are We Specified? Yes No

Return Date:

RETURN QUOTE

To Salesman: E-mail Mail Fax Hand

To Customer: E-mail Mail Fax Hand

FAX BACK TO: 01782 599220

CONVERSION DATA

	Metric To			Imperial	To Metric		
Weight	g	× 0.0353	=	oz	× 28.35	= g	
	kg	× 2.205	=	lb	× 0.4536	= kg	
	kg	× 0.0098	=	ton	× 1016	= kg	
Volume	cm ³	× 0.61	=	ins ³	× 16.39	= cm ³	
	m ³	× 35.32	=	ft ³	× 0.0283	= m ³	
	m ³	× 1.308	=	yds ³	× 0.7645	= m ³	
	litres	× 1.76	=	pints	× 0.568	= litres	
	litres	× 0.2205	=	gallons	× 4.546	= litres	
Area	cm ²	× 0.155	=	ins ²	× 6.452	= cm ²	
	m ²	× 10.76	=	ft ²	× 0.929	= m ²	
	m ²	× 1.196	=	yds ²	× 0.8361	= m ²	
	km ²	× 0.386	=	acres	× 0.4047	= km ²	
Velocity	m/s	× 196.85	=	ft./min	× 0.00508	= m/s	
	km/h	× 0.6214	=	mph	× 1.609	= km/h	
Heat	kW	× 3412	=	Btu/h	× 0.000293	= kW	
	J/kg	× 0.00043	=	Btu/h	× 2326	= J/kg	
	kCal/h	× 3.968	=	Btu/h	× 0.252	= kCal/h	
Flow	m ³ /s	× 2119	=	cfm	× 0.000472	= m ³ /s	
	m ³ /h	× 0.589	=	cfm	× 1.699	= m ³ /h	
	m ³ /s	× 13210	=	gpm	× 0.0000758	= m ³ /s	
	l/s	× 13.21	=	gpm	× 0.0758	= l/s	
Pressure	N/m ²	× 0.004	=	ins. wg.	× 249.1	= N/m ²	
	Pa	× 0.004	=	ins. wg.	× 249.1	= Pa	
	mbar	× 0.401	=	ins. wg.	× 2.491	= mbar	
	kp/m ²	× 0.394	=	ins. wg.	× 25.4	= kp/m ²	
	mbar	× 0.00099	=	atmos	× 1013	= mbar	
	bar	× 14.51	=	p.s.i.	× 0.0689	= bar	
Length	mm	× 0.0394	=	ins.	× 25.4	= mm	
	m	× 3.281	=	ft.	× 0.3048	= m	
	m	× 1.094	=	yds.	× 0.9133	= m	
	km	× 0.6214	=	miles	× 1.609	= km	
Various	kW	× 1.34	=	hp	× 0.746	= kW	
	m ³ /kg	× 16.03	=	ft ³ /lb	× 0.0264	= m ³ /kg	
	°C	× 1.8 + 32	=	°F	- 32 ÷ 1.8	= °C	

PRODUCT RANGES

Air-cooled & Water-cooled Liquid Chillers
Packaged Roof-Top Units
Fan Coils & VAV
Package Telecommunications Units
Fresh Air Units
Condensing Units
Air Cooled Condensers
Low Temperature Cassettes
Cellar & Storage Low Temperature Cooling Units
Packaged In-Wall Units
Stand-alone Humidifiers
OEM Process Cooling Control Units
Custom Designed Packages
Air Terminal Devices

MODUCEL

Eaton-Williams Air Conditioning

Oldfields Business Park
Birrell Street, Fenton
Stoke-on-Trent ST4 3ES
Telephone: +44 (0)1782 599995
Facsimile: +44 (0)1782 599220
www.eaton-williams.com



We reserve the right to alter specifications without notice and products will sometimes be supplied with modifications which do not strictly comply with the descriptions and illustrations in this publication.

0411112 LKP /4.04/1