

# COLMAN MODUCEL

E N G I N E E R E D   A I R   D I S T R I B U T I O N

## LAMINAR FLOW PANELS P SERIES

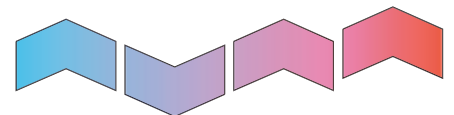
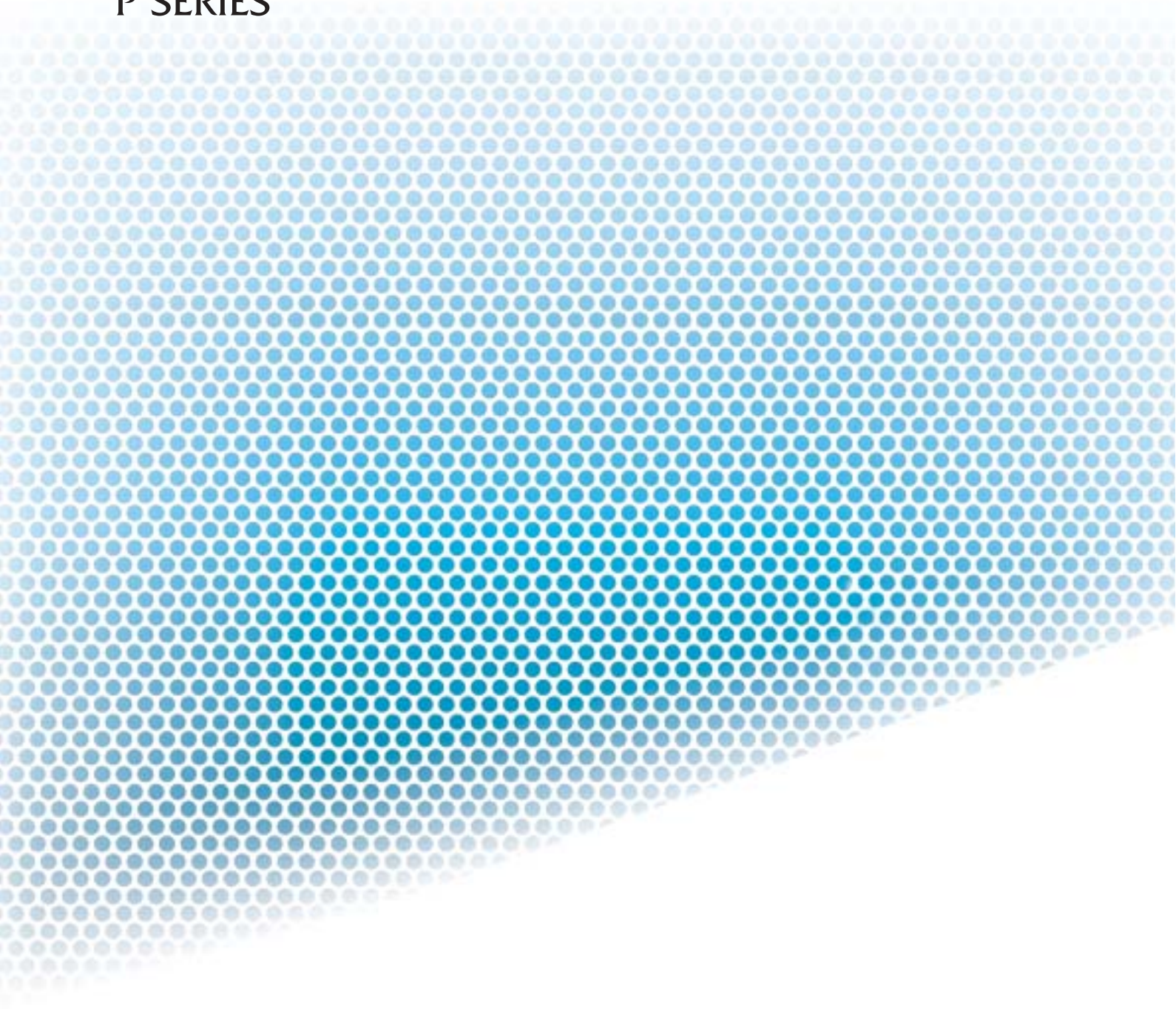

# P SERIES LAMINAR FLOW PANELS

## QUALITY AND EFFICIENCY WITHOUT COMPROMISE

### Application

Designed for use in specialist applications where the mixing of fresh and existing room air and the subsequent spreading of airborne particles cannot be tolerated, the Colman Modulac laminar flow systems provide very low turbulence fresh air in a vertical flow pattern, avoiding up-currents and providing a clean, germ-free air zone. They are therefore ideally suited for use in hospital operating theatres, laboratories, computer rooms and television studios amongst others. The system can be matched to the room design so that it can either form the whole ceiling arrangement incorporating light fittings and other items or it can be a single panel where a particular zone requires special conditions. As it can provide fresh air over a wide space it is also suited to applications where standard diffusers cannot provide the air change capacity needed.



Typical installation of Laminar Flow Panels

### Description

The panels comprise a perforated aluminium sheet with an extruded aluminium frame and galvanised steel plenum with top entry spigot. Dampers are not recommended in the entry spigot due to noise limitations and they should be fitted in the upstream ductwork. When individual panels are supplied the plenums are formed by enclosing the back of the frames with a panel and having a separate spigot for each sub-unit.

### Fixings

For individual panels, the PF diffuser is suited for laying in a T bar ceiling system, the PC diffuser is fitted with a surface mounted frame design and the PD with a recessed mounted frame. Both the PC and PD are supplied with side suspension brackets for use with drop rods or suspension wires. Special fixing arrangements are available on request.

For multi-panel assemblies provision is made on the frame for suspending the whole unit and details of typical fixings are given within this brochure. Normal fixing is via adjustable rods from the ceiling slab.

### Finish

The panel is available as standard, powder coated in RAL 9010 Matt White. Please refer to the product coding section within this brochure for a list of other standard finishes. Special finishes are available on request.

Model PF Tee bar mounted

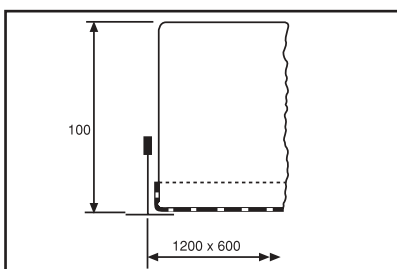

Model PC Surface mounting frame

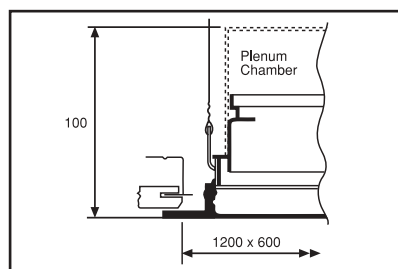

Model PD Recessed mounted frame

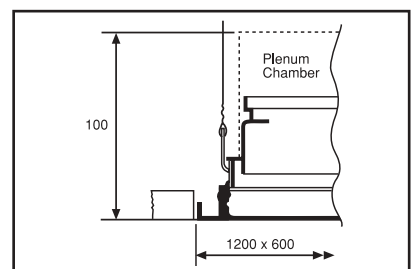

# Options and Order Codes

## Laminar Flow Panels

1	2 FRAME	3 PLENUM TYPE	4 ACCESSORIES	5 ARRANGEMENT	6 FIXING	7 FINISH
<b>P</b>	O None A Laminar flo-removable facplate C Laminar flo-faceplate with surface mounting frame D Laminar flo-faceplate with recessed mounting frame F Laminar flo-tee bar mounting 1 Special	O None R Round Neck S Square Neck	O None 1 Special	O None 1 Special	O None A Screw thru neck B Side support brackets Peur 1018 1 Special	F RAL9010 Matt White Other standard colours available ; Mill Finish O BS00E55 Gloss White C BS00E55 Satin White H BS00E55 Matt White D RAL9010 Gloss White E RAL9010 Satin White G RAL9006 Aluminium 3 Special Colours available on request 1

Note: The items shown in red print above and in the order code example below are the standard options for this product. Unless shown otherwise on any quotation or order the units will be supplied in this configuration.

### Example of Order Codes

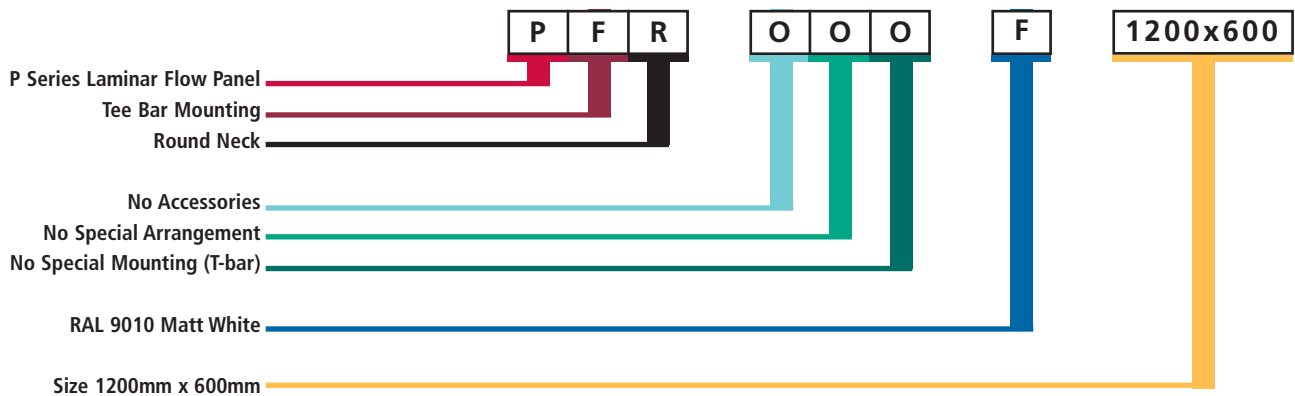

### Selection Information

#### Individual Panels PF, PC, PD

The figures given in table 1 are for a 1200mm x 600mm panel with a single central 300mm spigot lying on a tee bar with a 12mm overlap all round. The pressure drop is the static pressure in the spigot and a room allowance of 8dB has been assumed for the NC ratings.

Table 1

Air Volume m <sup>3</sup> /s	Face Velocity m/s	sPs Pa	NC
0.070	0.10	2	-
0.085	0.125	3	-
0.100	0.15	5	15
0.115	0.175	6	18
0.130	0.20	8	22
0.145	0.225	10	26
0.160	0.25	12	32
0.175	0.275	15	33
0.190	0.30	18	36
0.205	0.35	20	39

#### Multi-panel Assemblies PA

The mean face velocity of fresh air around a typical operating table should be 0.08 to 0.12 m/s with the optimum figure being 0.1 m/s with a cooling differential of 5 to 9°C. Table 2 gives figures for total air volumes of typical ceiling panel assemblies within this range. The nominal size figure allows for a 600mm square panel at the centre of the panel for a light fitting. The NC figure is for a panel at 0.12 m/s face velocity with the measurement taken 1m below the panel and with a 2 dB room allowance.

Table 2

Face Velocity m/s	Nominal assembly size			
	2.4x 1.8m	2.4x 3.0m	2.4x 4.2m	2.4x 5.4m
0.08	0.276	0.484	0.692	0.900
0.10	0.345	0.605	0.865	1.125
0.12	0.415	0.726	1.038	1.350
NC at 0.12 m/s	25	27	29	30

# Single Panel Assemblies

Section through model PF single panel

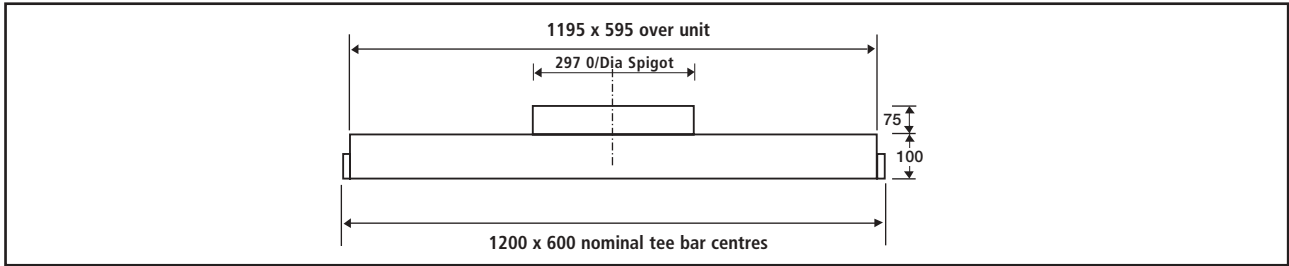

Section through model PAR single panel

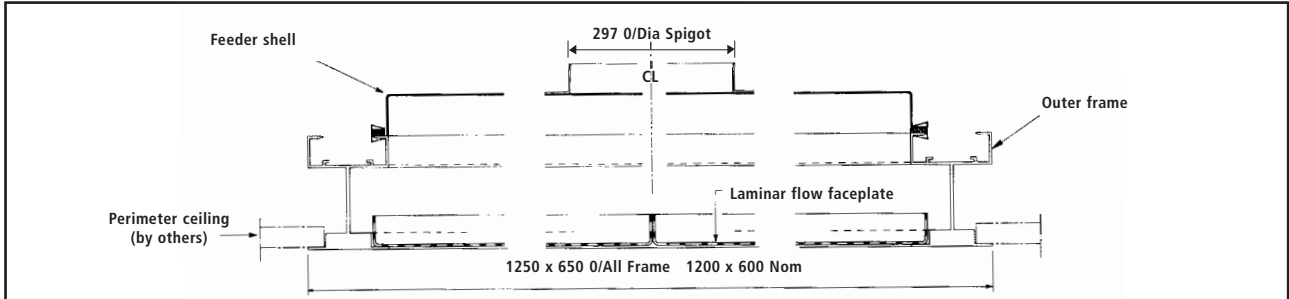

# Multi Panel Assemblies

5 Module Unit

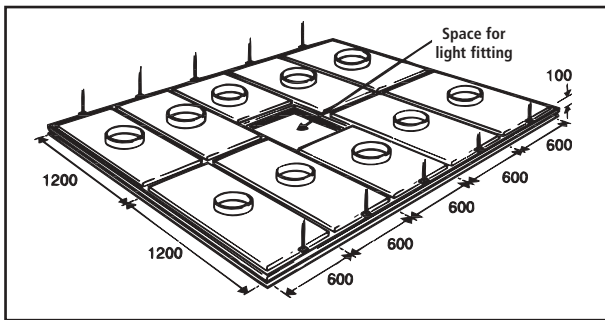

Multi-panel unit frame details surface mounting

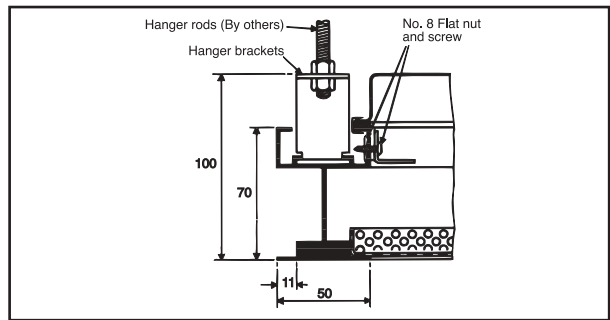

Multi-panel unit frame details surface mounting

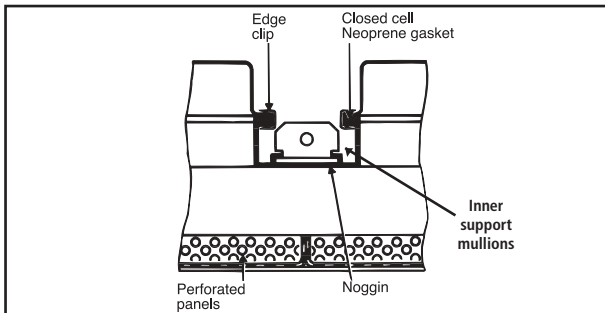

Detail showing operating light section

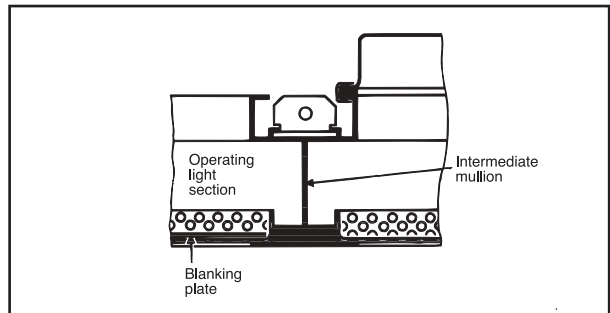

## SPECIFICATION:

A P Series Laminar Flow assembly comprising a perforated aluminium sheet with extruded aluminium frame and galvanised steel plenum and circular entry spigot. Perforated face plate to comprise 1.5mm thick aluminium sheet, extrusion to BS 1474/6063T6 and sheet metal 1mm thick.



Air Distribution and Air Handling

Oldfields Business Park  
 Birrell Street, Fenton  
 Stoke-on-Trent ST4 3ES  
 Telephone: +44 (0)1782 599995  
 Facsimile: +44 (0)1782 599220  
 email: colman.moducel@eaton-williams.com

