

**COLMAN**

ENGINEERED AIR DISTRIBUTION

**CIRCULAR DIFFUSERS**

**L SERIES**



**L**

**SERIES**

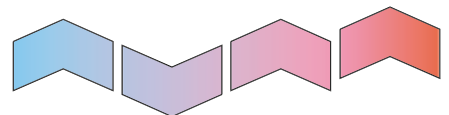

# CIRCULAR DIFFUSERS

## L SERIES

QUALITY AND EFFICIENCY WITHOUT COMPROMISE



### Application

Colman's L Series range of aluminium circular diffusers have been designed to provide an attractive and flexible solution to a wide variety of air distribution requirements. With adjustable cores, the range is suitable for most commercial or industrial applications.

### Description

The units are available in sizes starting from 150mm and increasing in increments of 50mm to a maximum size of 500mm. No size 450mm unit is available. The units have a wide multi-step adjustment of vanes allowing entirely horizontal or vertical air flows to be set depending on ceiling height. The units are manufactured from spun aluminium and can be supplied with optional equalising grids or volume control dampers.



### Finish

The units are supplied as standard in either RAL 9010 Gloss white or RAL 7035 Gloss light grey. Please refer to the product coding section within this brochure for a list of other standard finishes. Special finishes are available on request.

# Round Ceiling Diffusers with Adjustable Vanes

## Fixings

The diffusers are mounted with screws fixing through the neck ensuring a pleasing appearance. Optional dampers or equalising grids are also screw fixed in the connecting duct as illustrated.

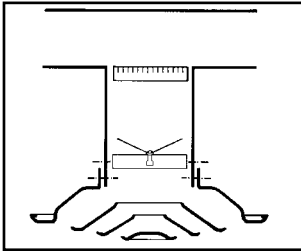

**Fig 1.**

Ceiling diffuser installation with equaliser and butterfly damper, connected to branch duct.

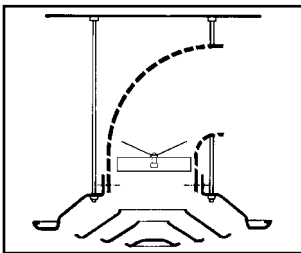

**Fig 2.**

Ceiling diffuser installation with butterfly damper, connected by flexible duct.

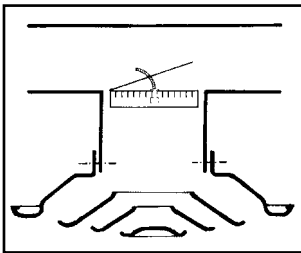

**Fig 3.**

Ceiling diffuser installation with slide damper, connected to branch duct.

## Mounting Instructions

### Ceiling diffuser

1. Take out inner vanes from diffuser pushing them inwards.
2. Fasten ceiling diffuser outer ring to connecting duct, with screws on diffuser neck.
3. Reset diffuser vanes within outer ring.
4. Adjust central vanes according to expected type of air diffusion.

### Equaliser

1. Mount the equaliser within the connecting duct, at its beginning from branch duct.
2. Fasten it with screws mounted on connecting duct outer circumference.

### Butterfly damper

1. Mount the damper within the connecting duct, near ceiling diffuser neck. Fasten it with screws mounted on connecting duct outer circumference.
2. Make preliminary adjustment. Final adjustment will be effected during system calibration, through diffuser central vane.

### Slide damper

1. Mount the damper within connecting duct, at its beginning from branch duct.
2. Fasten it with screws mounted outside connecting duct.
3. Make damper preliminary adjustment. Final adjustment will be made during system calibration, through ceiling diffuser central vane.

## Options and Order Codes

### Diffuser Codes

1	2 FRAME	3 CORE	4 ACCESSORIES	5 ARRANGEMENT	6 FIXING	7 FINISH
L	S Surface Mounted	R Removable Core	O None Q Butterfly Damper R Slide Damper Z Equalising Grid 1 Special	O None 1 Special	A Screw Through Neck 1 Special	None (Mill Finish) O RAL 9010 Gloss White E RAL 7035 Gloss Light Grey L Special 1

**Note:** The items shown in red above and in the order code example below are the standard options for this product. Unless shown otherwise on any quotation or order the units will be supplied in this configuration.

### Example of Order Codes

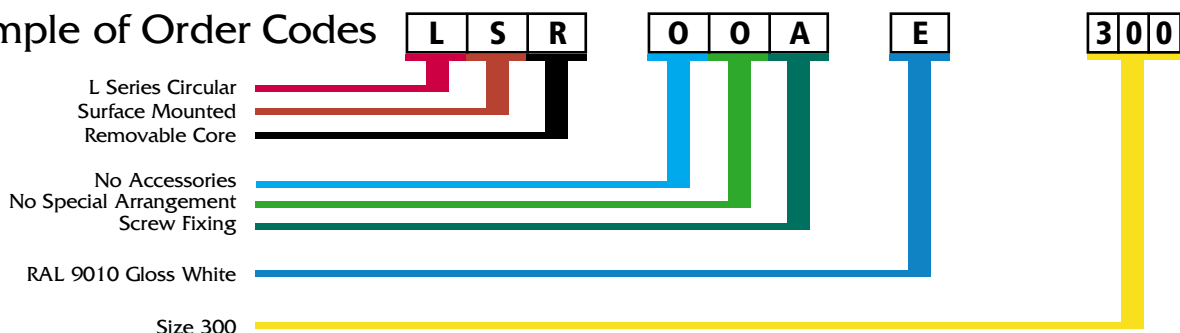

# Selection Information

The following pages give details on how to correctly select the L Series Diffusers, together with a worked example. Please read the notes carefully and contact us should you have any queries.

## Throw

If two diffusers are to throw towards each other, select an air volume that gives a maximum throw equal to half the distance between the two. Minimum throw should be used when discharging towards a wall or window. Where not influenced by a ceiling, throw is reduced by 40%. On heating applications the diffusers are suitable for 'spot' heating and do not give comfort conditions in the occupied zone.

## Connections and Dampers

Figures given are based on correctly aligned connections and good air approach to the diffuser with fully open dampers. If connections are misaligned or dampers are used for purposes other than fine tuning, noise and pressure figures will increase greatly.

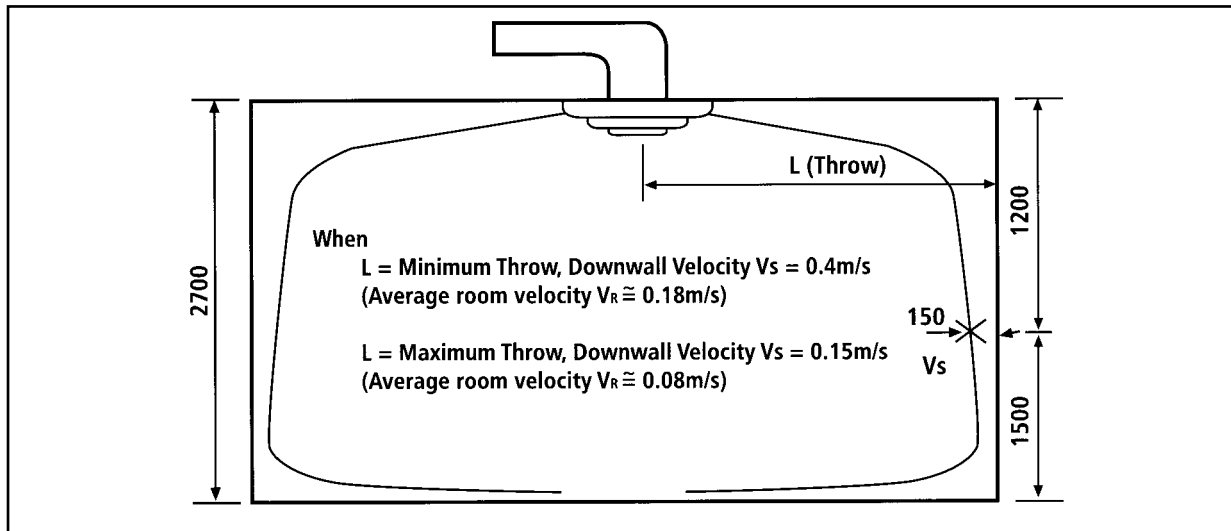

## Typical Selection

Given: Zone Size of 5m x 5m x 2.7m high  
Required NR level of 30  
10 Air changes per Hour

### 1) Calculate Air Volume required:

Room Volume = Length - 5m x Width  
- 5m x Height - 2.7m = 67.5m<sup>3</sup>

Multiplied by the required number of air changes  
- 10 = 675m<sup>3</sup>/hr

Divided by the number of seconds per hour  
- 3600 = 0.188m<sup>3</sup>/s

### 2) Decide position of Diffuser:

Assuming the diffuser is positioned centrally in the zone a throw of 2.5m would be required to fully distribute the air in the room.

### 3) Select Diffuser:

From the performance data given in the table on page 5 a 250dia diffuser with a volume of 180l/s would give a throw of between 1.8m and 3.3m, at NR27, as selections should be based on mid range, this diffuser would be suitable in this instance.

**Note: Although the basic selection is now made the points shown below should be checked.**

### Check No. 1 - Ceiling Height

For ceiling heights greater than 2.7m, the throw is reduced by 5% for each additional 0.3m up to a maximum ceiling height of 4.3m.

## Change to pressure drop and NR rating for vertical projection

	Ps	NR
150	x1.5	+4
200	x2.6	+8
250	x2.9	+10
300	x2.8	+12
350	x3.2	+9
400	x2.2	+8
500	x9.0	+10

# LSR Vertical Supply

Diffuser size (mm)	Δt°C	Minimum air volume required to project warm air to floor - l/s														
		Diffuser Mounting Height - (m)														
		2.70	3.10	3.70	4.30	4.90	5.50	6.10	6.70	7.30	7.90	8.50	9.10	9.80	10.40	11.00
200	5.5	075	083	094	108	125	137	146								
	11	108	118	137	156	179	193	208								
	22	156	170	198	226	257	283	292								
	33	205	217	255	288	318	354	378								
250	5.5		137	158	177	194	215	236	255	274						
	11		186	215	238	264	288	316	340	364						
	22		255	293	328	361	401	437	472	500						
	33		316	364	401	444	486	538	570	618						
300	5.5		161	175	184	208	231	250	274	293	316	345				
	11		212	243	281	314	345	373	415	444	472	512				
	22		295	345	382	434	481	524	578	618	651	712				
	33		373	432	491	552	604	665	729	792	804					
350	5.5			198	246	269	312	335	378	420	458	496	533	580		
	11			279	345	387	430	495	534	604	665	750	814	915		
	22			444	496	552	656	797	849	948						
	33			514	653	773	882	1,010								
400	5.5			269	316	363	427	483	545	618	693	764	915	1,010	1,130	1,250
	11			424	510	618	721	899	1,060	1,240	1,350					
	22			632	810	1,050	1,280	1,520								
	33			939	1,240	1,523										
500	5.5				655	778	882	1,040	1,170	1,410	1,560	1,850	2,140			
	11				1,400	1,520	1,850	2,250								

1. Performances are for diffuser without damper 100% open.

# LSR Horizontal Supply

Volume (l/s)	Size	Neck Velocity (m/s)	Pressure Drop Ps (Pa)	Min Throw (m)	Max Throw (m)	Sound Ranking NR
40	150	2.2	4	0.6	1.0	<
50	150	2.8	6	0.9	1.4	<
60	150	3.4	8	1.1	1.8	15
	200	1.9	3	0.7	1.2	<
70	150	4.0	12	1.3	2.2	20
	200	2.3	4	0.8	1.5	<
80	150	4.5	15	1.5	2.7	24
	200	2.5	5	1.0	1.7	<
90	150	5.1	19	1.7	3.1	28
	200	2.9	6	1.1	2	<
100	150	6.2	24	1.9	3.5	32
	200	3.2	8	1.2	2.2	15
	250	2.0	4	1.0	1.8	<
120	150	6.8	34	2.3	4.3	40
	200	3.8	11	1.5	2.8	21
	250	2.4	5	1.2	2.2	<
140	200	4.5	15	1.8	3.3	27
	250	2.9	8	1.4	2.5	19
	300	2.0	2	1.2	2.1	<
160	200	5.1	19	2.1	3.8	32
	250	3.3	10	1.6	2.9	23
	300	2.3	3	1.3	2.4	>
180	200	5.7	24	2.4	4.3	37
	250	3.7	13	1.8	3.3	27
	300	2.5	3	1.5	2.7	<
200	200	6.4	31	2.7	4.9	41
	250	4.1	16	2.0	3.6	30
	300	2.8	4	1.7	3.0	16
	350	2.1	2	1.5	2.8	<
225	250	4.6	19	2.3	4.1	34
	300	3.2	5	1.9	3.4	20
	350	2.3	3	1.7	3.1	<
250	250	5.1	24	2.5	4.6	37
	300	3.5	6	2.1	3.8	24
	350	2.6	4	1.8	3.3	<
	400	2.0	3	1.7	3.0	<
275	250	5.6	29	2.8	5.0	40
	300	3.9	7	2.3	4.2	27
	350	2.9	5	2.0	3.6	<
	400	2.2	4	1.8	3.3	<

Volume (l/s)	Size	Neck Velocity (m/s)	Pressure Drop Ps (Pa)	Min Throw (m)	Max Throw (m)	Sound Ranking NR
300	250	6.1	36	3.1	5.5	43
	300	4.2	9	2.5	4.5	30
	350	3.1	7	2.2	3.9	<
	400	2.4	5	2.0	3.5	<
325	250	6.6	42	3.3	6	45
	300	4.6	10	2.7	4.9	33
	350	3.4	8	2.3	4.2	16
	400	2.6	5	2.1	3.8	<
350	250	7.1	48	3.6	6.4	48
	300	5.0	12	2.9	5.3	35
	350	3.6	10	2.5	4.5	18
	400	2.8	6	2.2	4.0	<
400	300	5.7	16	3.3	6.1	40
	350	4.2	13	2.8	5.1	23
	400	3.2	8	2.5	4.5	18
	500	2.0	1	2.0	3.7	<
450	300	6.4	20	3.7	6.8	44
	350	4.7	16	3.1	5.6	28
	400	3.6	10	2.8	5.0	23
	500	2.3	1	2.2	4.0	<
500	300	7.1	24	4.1	7.6	48
	350	5.2	20	3.5	6.2	32
	400	4.0	13	3.1	5.5	26
	500	2.5	1	2.4	4.3	<
600	350	6.2	28	4.1	7.3	40
	400	4.8	18	3.6	6.4	33
	500	3.1	1	2.7	4.9	<
700	400	5.6	24	4.2	7.4	38
	500	3.6	2	3.1	5.5	18
800	400	6.4	32	4.7	8.4	43
	500	4.1	2	3.5	6.2	24
900	500	4.6	3	3.9	6.8	27
1000	500	5.1	4	4.2	7.4	31
1100	500	6.1	6	5.0	8.7	38
1200	500	6.1	6	5.0	8.7	38
1300	500	6.6	7	5.4	9.3	40

NR Levels include allowance of 8dB for room absorption.

### Diffuser Dimensions

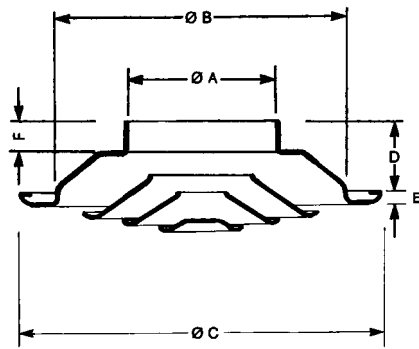

Nominal Diameter Dn (mm)	ØA	ØB	ØC	D	E	F	Approx Weight kg
150	153	295	345	60	11	25	0.8
200	203	380	445	70	13	25	1.25
250	253	475	565	105	15	35	2.0
300	303	570	665	115	17	35	2.6
350	353	665	760	135	19	40	4.0
400	403	760	900	165	21	50	5.0
500	503	940	1105	210	23	50	7.0

### Order Code: Z Equalising Grid

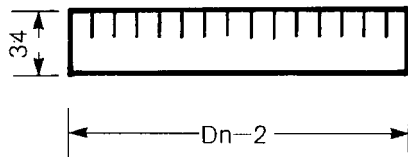

Nominal Diameter Dn (mm)		Approx Weight kg
150		0.35
200		0.45
250		0.60
300	<b>Diameter = Nominal - 2mm</b>	0.85
350		1.10
400		1.40
500		1.80

### Order Code: Q Butterfly Damper

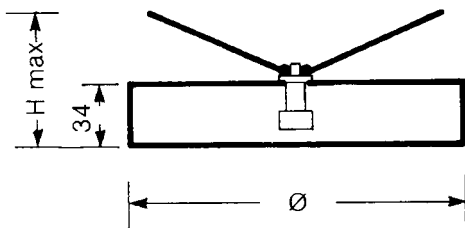

Nominal Diameter Dn (mm)	Ø	H max	Approx Weight kg
150	148	80	0.35
200	198	105	0.45
250	248	125	0.60
300	298	140	0.85
350	348	150	1.10
400	398	155	1.40
500	498	205	1.80

### Order Code: R Slide Damper

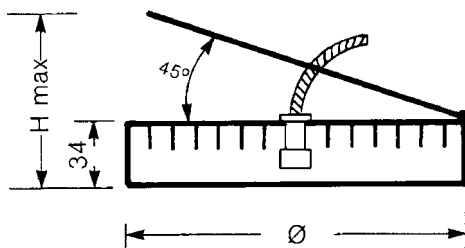

Nominal Diameter Dn (mm)	Ø	H max	Approx Weight kg
150	148	130	0.65
200	198	165	0.75
250	248	200	0.90
300	298	235	1.15
350	348	270	1.40
400	398	305	1.70
500	498	340	2.00



Air Distribution and Air Handling

Oldfields Business Park  
Birrell Street, Fenton  
Stoke-on-Trent ST4 3ES  
Telephone: +44 (0)1782 599995  
Facsimile: +44 (0)1782 332092  
email: colman.moducel@eaton-williams.com



Station Road, Edenbridge  
Kent TN8 6EG, England  
Telephone: +44 (0)1732 866055  
Facsimile: +44 (0)1732 869626  
www.eaton-williams.com